

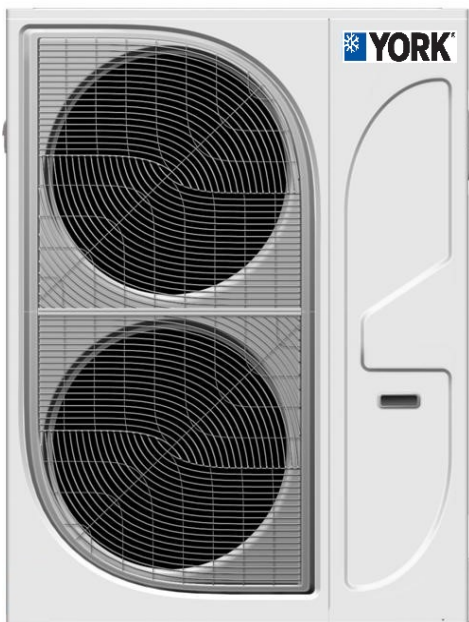


**DC INVERTER AIR-COOLED  
CHILLER AND HEAT PUMP**

Installation , Operation & Maintenance Manual

FORM NO.: 6U5M-A11M-NB-EN

YVAG012~040RSE



## Table of Contents

GENERAL SAFETY GUIDELINES .....	4
SECTION 1-PRODUCT DESCRIPTION.....	6
INTRODUCTION.....	6
BASIC UNIT NOMENCLATURE .....	6
THE UNIT DIMENSION.....	6
OPERATING RANGE.....	8
SECTION 2 –INSTALLATION REQUIREMENTS.....	9
INSPECTION.....	9
MOVING THE UNIT.....	9
INSPECTION CHECKLIST.....	10
HANDLING.....	10
LOCATION .....	11
FOUNDATION.....	11
INSTALL SPACING.....	13
INSTALLATION CLEARANCES.....	13
WATER SYSTEM INSTALLATION .....	15
UNIT EXTERNAL HEAD.....	21
ELECTRICAL CONNECTION .....	23
ACCESSORY DIMENSIONS .....	24
SECTION 3 –ELECTRICAL CONTINUITY .....	26
ELECTRICAL CONNECTION .....	26
ELECTRICAL DIAGRAM .....	27
ELECTRICAL SCHEMATIC DIAGRAM .....	35
SECTION 4 – WIRE CONTROLLER OPERATION .....	39
INTRODUCTION.....	39
INTERFACE .....	39
BASIC OPERATIONS.....	40
ADVANCED OPERATIONS.....	40
SECTION 5 – MAINTENANCE .....	46
IMPORTANT .....	46
COMPRESSORS.....	46
OIL CHARGE.....	46
ADD TROPICAL PREHEATING .....	46
JOHNSON CONTROLS .....	2

---

CONDENSER COILS.....	46
OPERATING PARAMETERS .....	46
CONDENSER FAN MOTORS .....	46
OVERALL UNIT INSPECTION .....	46
MODBUS PROTOCOL .....	47
TROUBLE SHOOTING.....	50
TROUBLE SHOOTING (CONT'D).....	51
POISONOUS AND HARMFUL SUBSTANCE CONTENT TABLE UNIT .....	52

## GENERAL SAFETY GUIDELINES

This equipment is a relatively complicated apparatus. During rigging, installation, operation, maintenance, or service, individuals may be exposed to certain components or conditions including, but not limited to: heavy objects, refrigerants, materials under pressure, rotating components, and both high and low voltage. Each of these items has the potential, if misused or handled improperly, to cause bodily injury or death. It is the obligation and responsibility of rigging, installation, and operating/service personnel to identify and recognize these inherent hazards, protect themselves, and proceed safely in completing their tasks. Failure to comply with any of these requirements could result in serious damage to the equipment and the property in which it is situated, as well as severe personal injury or death to themselves and people at the site.

This document is intended for use by owner-authorized rigging, installation, and operating/service personnel. It is expected that these individuals possess independent training that will enable them to perform their assigned tasks properly and safely. It is essential that, prior to performing any task on this equipment, this individual shall have read and understood the on-product labels, this document and any referenced materials. This individual shall also be familiar with and comply with all applicable industry and governmental standards and regulations pertaining to the task in question.

Pay attention to keep this document and you can acquire it from *local authorized YORK service center* in case it would be lost.

## SAFETY SYMBOLS

The following symbols are used in this document to alert the reader to specific situations:



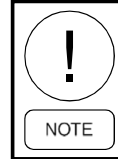
*Indicates a possible hazardous situation which will result in death or serious injury if proper care is not taken.*



*Identifies a hazard which could lead to damage to the machine, damage to other equipment and/or environmental pollution if proper care is not taken or instructions are not followed.*



*Indicates a potentially hazardous situation which will result in possible injuries or damage to equipment if proper care is not taken.*



*Highlights additional information useful to the technician in completing the work being performed properly.*



*External wiring, unless specified as an optional connection in the manufacturer's product line, is not to be connected inside the control cabinet. Devices such as relays, switches, transducers and controls and any external wiring must not be installed inside the micro panel. All wiring must be in accordance with Johnson Controls' published specifications and must be performed only by a qualified electrician. Johnson Controls will NOT be responsible for damage/problems resulting from improper connections to the controls or application of improper control signals. Failure to follow this warning will void the manufacturer's warranty and cause serious damage to property or personal injury.*

## CHANGEABILITY OF THIS DOCUMENT

In complying with Johnson Controls' policy for continuous product improvement, the information contained in this document is subject to change without notice. Johnson Controls makes no commitment to update or provide current information automatically to the manual or product owner. Updated manuals, if applicable, can be obtained by contacting the nearest Johnson Controls Service office or accessing the Johnson Controls website.

It is the responsibility of rigging, lifting, and operating/service personnel to verify the applicability of these documents to the equipment. If there is any question regarding the applicability of these documents, rigging,

lifting, and operating/service personnel should verify whether the equipment has been modified and if current literature is available from the owner of the equipment prior to performing any work on the chiller.

### CHANGE BARS

Revisions made to this document are indicated with a line along the left or right hand column in the area the revision was made. These revisions are to technical information and any other changes in spelling, grammar or formatting are not included.

**SECTION 1-PRODUCT DESCRIPTION**

**INTRODUCTION**

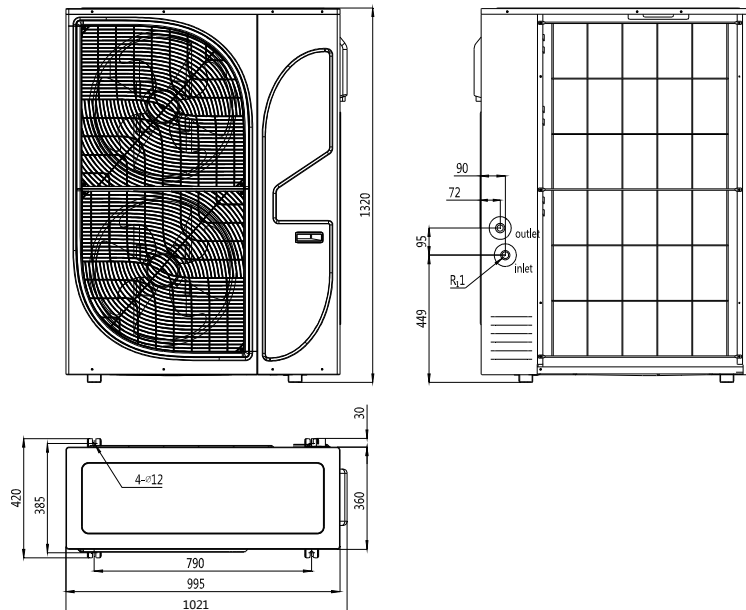
YORK **DC Inverter Air-Cooled Chiller** and Heat Pump Unit provide chilled water and hot water for all air conditioning applications using central station air handling or terminal units. They are completely self-contained and are designed for outdoor (roof or ground level) installation. Each complete packaged unit includes hermetic rotary compressors, a liquid cooler, air cooled condensers, a charge of refrigerant R410A and a weather resistant microprocessor control center, all mounted in a sheet metal shell.

**BASIC UNIT NOMENCLATURE**

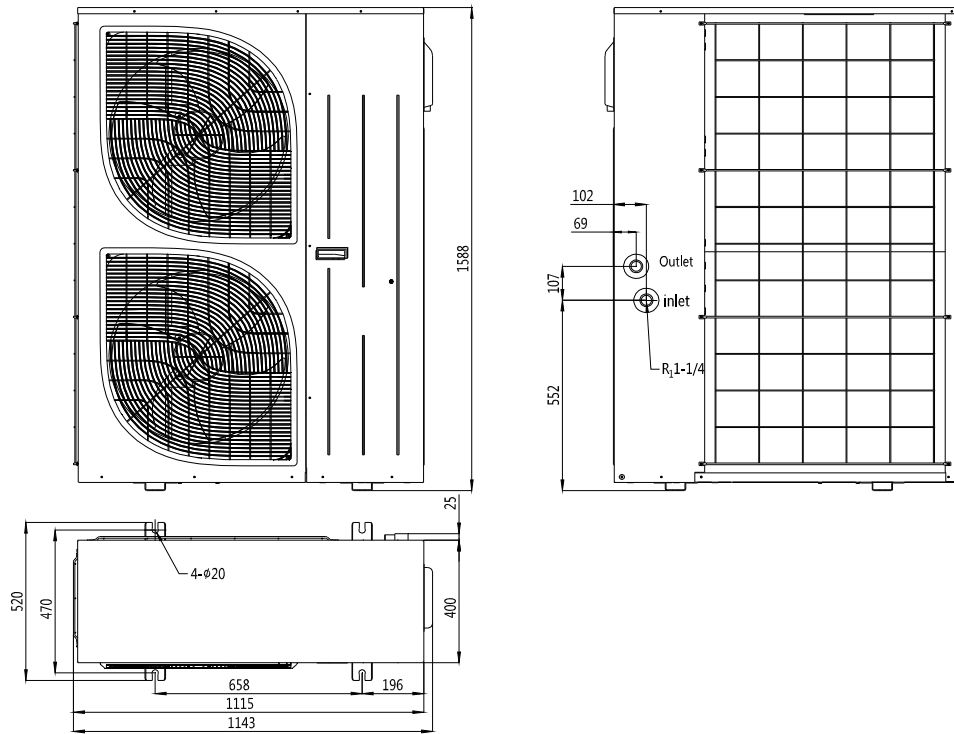
Named	Y	V	A	G	0	1	2	R	S	E	2	0
Number	1	2	3	4	5	6	7	8	9	10	11	12
The number 1:	Y-YORK											
The number 2:	V-Variable Frequency											
The number 3:	A -Air-cooled											
The number 4:	G-Design Series											
The number 5、6、7:	Nominal Capacity, (Unit: kW)											
The number 8:	Specific Function, R- Integral & Heat Pump											
The number 9:	Single/Modular, S- Single											
The number 10:	Refrigerant, E-R410a											
The number 11、12:	Voltage, 20- 220V ~50Hz , 50- 380V 3N~50Hz 30- 230V ~50Hz , 53- 400V 3N~50Hz											

**THE UNIT DIMENSION**

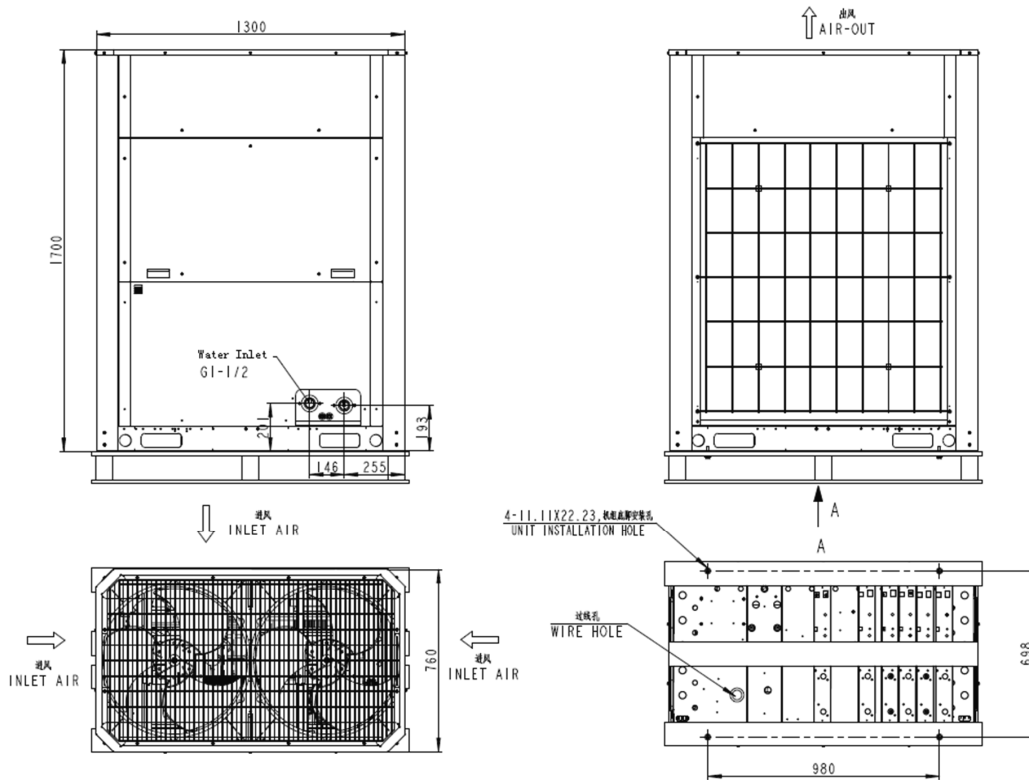
Unit: mm



**FIGURE 1 – YVAG012-018 DIMENSIONS**



**FIGURE 2** YVAG020-033 DIMENSIONS



**FIGURE 3** YVAG040 DIMENSIONS

## OPERATING RANGE

### Voltage Range

The maximum fluctuation range of supply voltage is  $\pm 10\%$

Three-phase electric phase unbalance rate should be less than 2%.

### Temperature range

**TABLE 1-Temperature range(YVAG012~040)**

Project	012~018	020~040
Relative humidity	<90%, No Ion	<90%, No Ion
Wire controller using the environment temperature	-10°C~55°C	-10°C~55°C
The unit running environment temperature range	Cooling -5°C~48°C Heating -20°C~43°C	Cooling -5°C~48°C Heating -25°C~43°C
Chilled water temperature range (Leaving water temperature)	Cooling 5°C~25°C Heating 30°C~52°C	Cooling 5°C~25°C Heating 30°C~58°C
Chilled water temperature range (Enter water temperature)	Cooling 10°C~30°C Heating 25°C~47°C	Cooling 10°C~30°C Heating 25°C~53°C

### Please note that



The return water temperature control is default by the unit controller, and return water temperature control is recommended.

The above data are obtained in the laboratory, the practical use there will be deviation affected by the installation position and so on.

For applications with temperature below -25°C, please consult YORK company.

### Applicable Medium

The standard design applicable medium of the unit is purified water. Please consult YORK Company for special medium such as glycol antifreeze fluid.

### Altitude


No more than 2000m

### Wind side external static pressure

No more than 30Pa



**SECTION 2 –INSTALLATION REQUIREMENTS**




# WARNING

Failure to follow these instructions could result in death, serious injury or equipment damage.

Follow all warnings and instructions in the unit's Manual(s).

<p><b>EN</b> Installation Instructions for the technician / fitter</p> <p><b>PL</b> Instrukcja instalacji dla technika / monter</p> <p><b>SV</b> Installationsguide för installatör / montör</p> <p><b>CS</b> Pokyny k instalaci pro techniky a montéry</p> <p><b>HU</b> Telepítési utasítás gyakorlott szervizmérnök / kivitelező részére</p>	<p><b>IT</b> Istruzioni d'installazione per il personale specializzato</p> <p><b>NL</b> Installatiehandleiding voor de vakman / monteur</p> <p><b>DE</b> Installationsanleitung für die Fachkraft / Monteur</p> <p><b>ES</b> Instrucciones de instalación para el técnico / contratista especializado</p> <p><b>PT</b> Instruções de instalação para o técnico / instalador</p>	<p><b>JA</b> 一般仕様・取扱説明書</p> <p><b>FR</b> Manuel d'installation pour le spécialiste / monteur</p> <p><b>RU</b> Инструкция по установке для техника/монтажника</p> <p><b>ZH</b> 适用于技术人员与安装人员的 安装说明书</p> <p><b>KO</b> 기술자 / 설비기술자에 대한 설치 지침</p>
--	---	--



1. Follow all applicable regulations and safety practices during rigging and lifting.
2. Prepare and follow written rigging and lifting plan.
3. Rigging must be directed by trained professional rigger.
4. Spreader bars must be used and be long enough to prevent rigging from contacting unit.
5. Use all and only designated lift points according to units manual(s).
6. Locate center of gravity through trial lifts to account for possible variations in unit configuration.
7. Use rigging and lifting techniques that keep unit stable and level.
8. Keep clear of unit when lifted.

035-23962-000 REV B

**INSPECTION**

Remove any transit packing and inspect the unit to ensure that all components have been delivered and that no damage has occurred during transit. If any damage is evident, it should be noted on the carrier's freight bill and a claim entered in accordance with the instructions given on the advice note.

Major damage must be reported immediately to your local Johnson Controls representative.

**MOVING THE UNIT**

Prior to moving the unit, ensure that the installation site is suitable for installing the unit and is easily capable of supporting the weight of the unit and all associated services.

The unit should be lifted using lifting lugs and a spreader bar or frame of sufficient width to prevent damage to the unit from the lifting chains.

The units shall be suitable for elevator or forklift truck or crane for convenience of lifting. When transporting

with a crane, a canvas hammock shall be used to come round the unit base and be fastened. If the packaging box has been removed, in order to move the machine, please apply suitable partition to protect the surface and the side panel, as shown in the picture below. During the transit, the machine shall be kept in level condition to avoid damaging the unit due to crude operation.

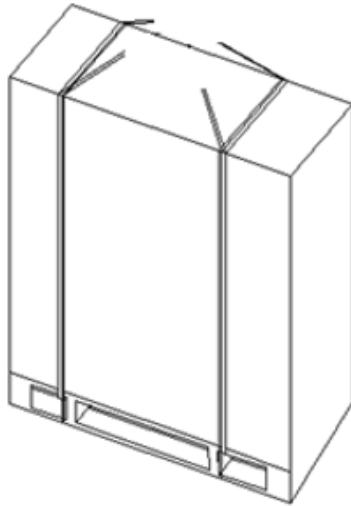


*Be particularly careful to ensure unit steady. Pay special attention to the weight distribution of the unit to avoid maldistribution and the center of gravity leans to the side of compressor. Please try once before hoisting and observe whether it is tightened and whether there is any risk of tip-over of the unit. The hoisting shall be slowly lifted with constant speed to avoid the tip-over of the unit and attention shall be paid to the security of personnel nearby.*

**TABLE 2 – PRODUCT WEIGHT**

Unit/Parameters		012	014	016/018	020/022/025	028/033	040
Gross weight	kg	136	138	151	220	225	360
Operating weight	kg	126	128	141	210	215	350

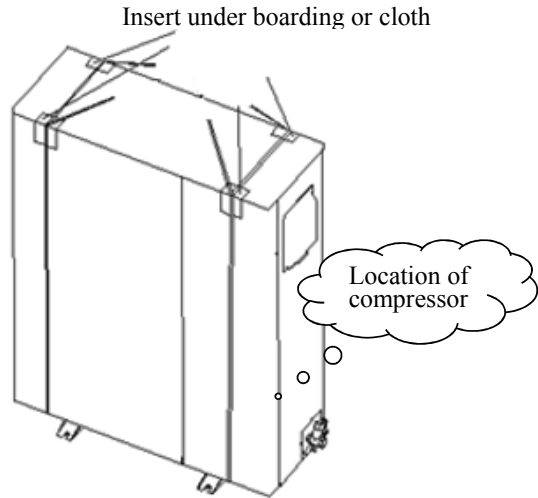
Schematic Diagram of Hoisting with Packaging



With a wooden cork base

Center of gravity of the unit inclined to one side, please hoisting according to the above picture and the requirements of installation manual. Please refer to the parameter list for the weight of the unit.

Schematic Diagram of Hoisting without Packaging



Without a wooden cork base

Center of gravity of the unit inclined to one side, please hoisting according to the above picture and the requirements of installation manual. Please refer to the parameter list for the weight of the unit.

**FIGURE 4 –HOISTING DIAGRAMMATIC DRAWING**



*To ensure warranty coverage, this equipment must be commissioned and serviced by an authorized YORK service mechanic or a qualified service person experienced in unit installation. Installation must comply with all applicable codes, particularly in regard to electrical wiring and other safety elements such as HP cutout settings, design working pressures, and ventilation requirements consistent with the amount and type of refrigerant charge.*

*Lethal voltages exist within the control panels. Before servicing, open and tag all disconnect switches.*

**INSPECTION CHECKLIST**

The following items, 1 through 4, must be checked before placing the units in operation.

1. The nameplate content of the unit is identical with the order;
2. The accompanying documents of the unit are complete;
3. The accessories of the unit are in accordance with the items listed in the packing list;
4. Immediately upon receiving the unit, it should be

inspected for possible damage which may have occurred during transit. If damage is evident, it should be noted in the carrier's freight bill. A written request for inspection by the carrier's agent should be made at once.

**HANDLING**

These units are shipped as completely assembled units containing full operating charge, and care should be taken to avoid damage due to rough handling.

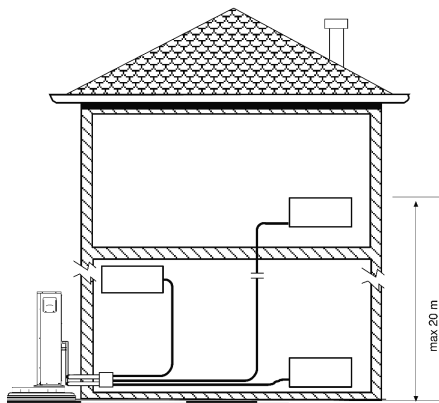
## LOCATION

These units are designed for outdoor installations on ground level, rooftop, balcony, and any other place that is suitable for installation with reliable load bearing. Location should be selected for minimum sun exposure and away from boiler flues and other sources of airborne corrosive or flammable gas that could attack the ambient coils and steel parts of the unit. The units must be installed with sufficient clearances for air entrance to the condenser coil to ensure adequate supply of fresh air, for air discharge away from the condenser, and for servicing access.

If the units are located at a place where unauthorized personnel could reach, isolation security measures shall be taken, such as setting protective guard, to avoid human sabotage and prevent the control cabinet from being opened and the operating electrical component from being exposed;

The highest point of the air conditioning system shall not be 20m over the unit (for 20m higher, please consult YORK Company);

In installations where winter operation is intended and snow accumulations are expected, additional height must be provided to ensure normal condenser air flow.



*For places with special installation requirements, please consult to the building contractor or the architect and designer or other professionals.*

## Noise Sensitive Locations

Efforts should be made to assure that the unit is not located next to occupied spaces or noise sensitive areas where unit noise level would be a problem.

Please make the unit face the place that is sensitive to noise as far as possible to reduce the influence of operating noise of the unit;

If the heat exchanger part is without block, protective baffle plate can be added to reduce the influence of operating noise of the unit.

## Cold Climate Locations

If the unit is operating in low ambient temperature, be sure to follow the instructions listed below.

1. A baffle plate installed on the airside of the unit is recommended to prevent exposure to snow in winter.
2. In areas with large snow precipitation, make sure the coil and fan will not be affected by the snow. Construct a lateral canopy if necessary.
3. Deice before operating if the fan blades fail to rotate after long time standby in snow.

## FOUNDATION

The unit should be mounted on a flat and level foundation, floor, or rooftop capable of supporting the entire operating weight of the equipment. See PHYSICAL DATA for operating weight. If the unit is elevated beyond the normal reach of service personnel, a suitable catwalk must be capable of supporting service personnel, their equipment, and the compressors.

To ensure the outdoor unit is placed flat on the base, the outdoor unit must be placed after confirming the plane where the outdoor unit would be placed is even. After the installation of the outdoor unit the outdoor unit shall be examined whether it is leveled, and the angle of inclination shall be smaller than 10°; for a unit with an absorber, the level inspection shall be installed after the installation of absorber;

There are installing holes on the foundation of the unit, and they can be used to closely connect the unit and the foundation;

## Ground location

For the ground installation, the steel foundation of the unit shall be placed on smooth and flat concrete foundation. DO NOT connect the unit foundation with the building foundation for fear that noise and vibration would be transmitted;

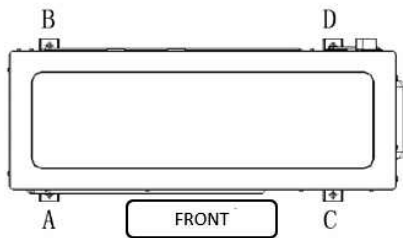
**Roof location**

If the unit is installed on the roof, the roof must have sufficient strength to support the weight of the unit and maintainer. The unit can be placed on the concrete foundation that is for the similar ground installation or on a box iron shelf;

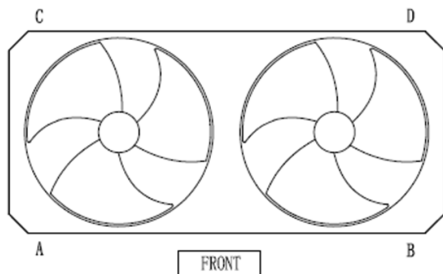
**Isolators (optional)**

It is recommended to place damped spring vibration isolator (especially for units with rack mounting or installed on the roof floor) between the base and the foundation of the outdoor unit. The isolator mounting shall be selected and installed according to design requirements to satisfy the demand of vibration isolation and to avoid phenomena including solid-borne sound transmission and resonance; generally the construction shall be undertaken by professionals with the models provided by the design engineer; the table below is the recommended model selection of absorber, a proximal absorber can be selected near the given optimal load and vertical stiffness:

**YVAG012~033:**



**YVAG040:**



**TABLE 3 – ABSORBER SELECT**

Unit	Total No. of isolators	Optimal Load of A/B Side (kg)	Optimal Load of C/D Side (kg)
YVAG 012~018	4	20	65
YVAG 020~033	4	35	80
YVAG040	4	150/110	110

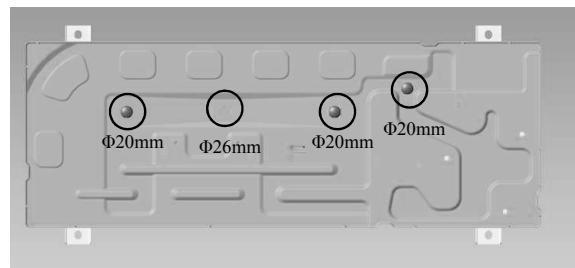
**Draining**

There should be drainage way around the unit so that the rainwater and water generated from heating for defrosting and heating condensation can be discharged; if there is no drainage way, please add water pond on the bottom of the unit and lead it with pipeline to a suitable place.

**1. Drainage way (012~018)**

There is a 26mm and three 20mm drain holes on the bottom of the base plate. For units that need centralized drainage in warmer district, block the three 20mm holes with the incidental drain plugs of the unit, and install

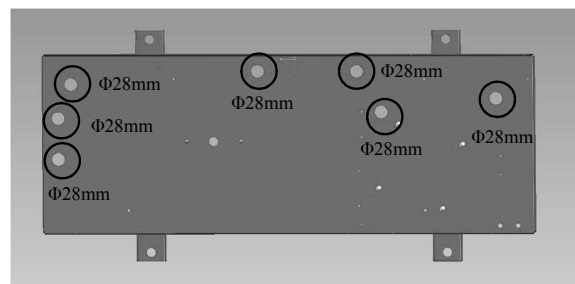
The drainage joint into the 26mm hole and connect suitable hosepipe to discharge the condensed water to the centralized drainage place. For units need centralized drainage in severe cold area, the drain pan need to be designed on site; the drain hole on the base plate could not be blocked, or it would lead to freezing due to impeded drainage of the base plate.



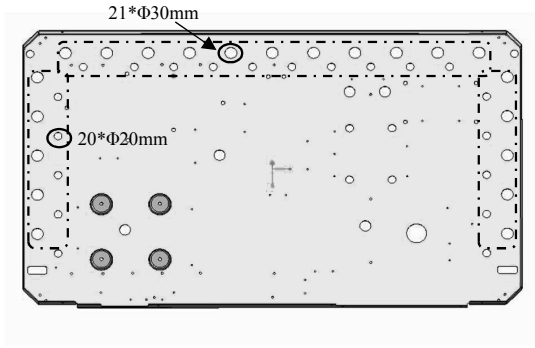
**FIGURE 5-BACKPLANE SCHEMATIC (012~018)**

**2. Drainage way (020~040)**

YVAG020~033 without drainage way, please add water pond on the bottom of the unit and lead it with pipeline to a suitable place.



**FIGURE 6-BACKPLANE SCHEMATIC (020~033)**



**FIGURE 7-BACKPLANE SCHEMATIC (040)**

**Compressor mounting**

The compressor is mounted on four (4) rubber or steel isolators. The mounting bolts should not be loosened or adjusted during installation of the unit.

**INSTALL SPACING**

Placement on a level surface of free of obstructions (including snow, for winter operation) or air circulation ensures rated performance, reliable operation, and ease of maintenance. Site restrictions may compromise minimum clearances indicated above, resulting in unpredictable airflow patterns and possible diminished performance. YORK’s unit control will optimize

operation without nuisance high-pressure safety cutouts; however, the system designer must consider potential performance degradation.

The influence of downward flow caused by tall buildings around the unit toward the exhaust air of the unit shall also be taken into consideration in installation.

If the unit is installed at a place with violent airflow, such as exposed roof, measures including parapet or blinds shall be taken to prevent turbulent flow from interfering the air flow into the unit. If the unit needs to set parapet, the height shall not be taller than the unit and the clearance between the unit and the parapet or the blinds shall also satisfy the minimum clearance requirement for unit installation.

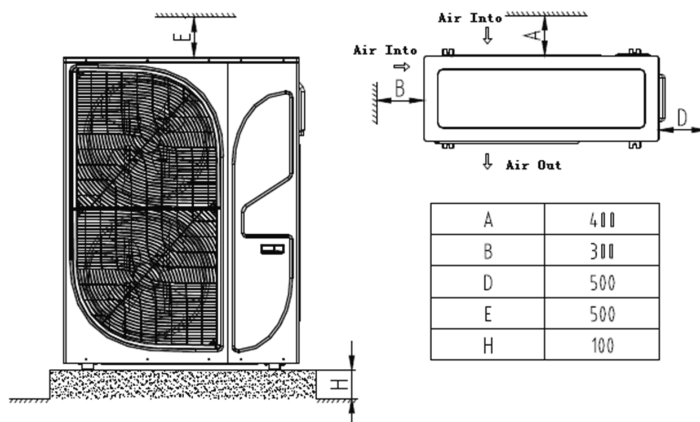
When the unit is placed on a snow covered surface, the bottom face of the unit should be at least 100mm higher than the surface of the snow cover to guarantee the air successfully flow through the coil exchanger.

No obstructions allowed in front of the airflow outlet except grilling of blinds. The effective aperture opening ratio of the grating shall be over 80% and the angle of inclination of the grating blades shall be over 20°, and the blade pitch shall be over 100mm

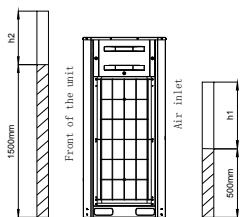
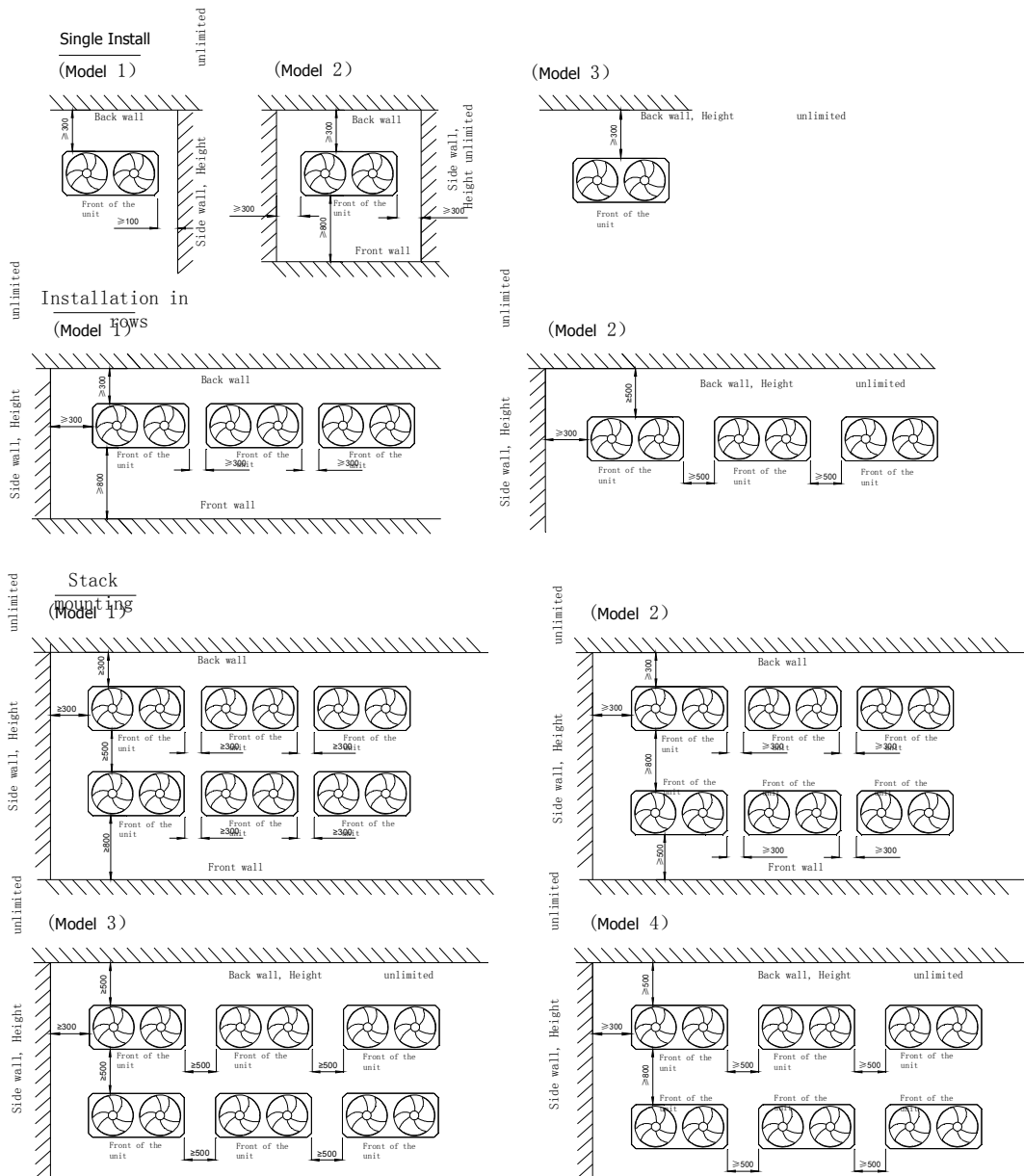
**INSTALLATION CLEARANCES**

Units are surrounded by walls or other obstacles, installation spacing, referring to the following figure.

YVAG012~033



**YVAG040**



**注:**

1. The above data unit is mm;
2. With the exception of special instructions, the high wall limits for each mode are: Front Wall: 1500mm; Back Wall: 500mm; Side Wall: Height unlimited  
The installation space shown in the figure depends on the outdoor temperature of 35 degrees in the refrigeration operation. When the specified outdoor temperature exceeds 35 degrees or when the heat of all outdoor machines exceeds the maximum allowable value, Should be above the suction side of the space increases.
3. If the above the wall is higher than the h1 and h2, should be in at right side entry and suction side to increase the h2/2 and h1/2 spare space.
4. In order to obtain the most appropriate space, should bear in mind that in the machine and the wall between the pedestrian to set aside enough, and to ensure smooth flow channel. ( More than the number of the mode of air conditioners, when installation should consider the possibility of airflow short circuit. )
5. On-site installation of air conditioning, should set aside enough space in front of the machine to facilitate pipe laying road.

**FIGURE 8- INSTALLATION SPACE DIAGRAM**

## WATER SYSTEM INSTALLATION

### Chilled liquid piping specification

**General** – When the unit(s) has been located in its final position, the unit water piping may be connected. Normal installation precautions should be observed in order to receive maximum operating efficiencies. All chilled water evaporator piping must comply with local plumbing codes and ordinances in all aspects.

Since elbows, tees and valves decrease pump capacity, all piping should be kept as straight and as simple as possible. All piping must be supported independent of the unit.

The following considerations of piping specification should be observed:

- a) The pipe diameter of the pipes inlet and outlet unit shall not be smaller than the joint specification (DN25). Also piping of DN32 or above is recommended
- b) Piping to the inlet and outlet connections of the unit should include high-pressure rubber hose or piping loops to ensure against transmission of water pump vibration. The necessary components must be obtained in the field.
- c) PP-R material is recommended for the water supply and return piping of the unit for the household water system. It will be beneficial, as the possibility of the filth blockage and the water resistance will decrease.
- d) Galvanized steel pipe (not recommended) shall be designed as screwed connection. When the pipe diameter is larger than DN100, clamp, flange or welded joint can be applied for connection.
- e) For welded connection (not recommended) applied for piping, antiseptic treatment (rust cleaning before painting) shall be conducted to the surface of welded joint and heat-affected area.
- f) Galvanized steel piping, PP-R piping and the corresponding screwed joints are indicated in piping specification of TABLE 2, and just for reference only.

### Chilled liquid piping installation

Water pipeline connection shall observe relevant installation regulations. Piping should be kept free of foreign matter.

The piping to and from the chiller must be designed to suit the individual installation. It is important that the following considerations are observed:

- a) The operating flow rate of the unit shall not exceed 40% of rated flow for each unit type, too large or too small water flow rate would affect the normal use of the unit.
- b) The water flow direction of the unit shall be connected according to the inlet and outlet pipe marks on the unit, otherwise the performance of the unit might be affected.
- c) The pipeline must have independent support and should not be placed on the unit.
- d) Hand stop valves, thermometers and pressure gauges should be installed in both inlet and outlet line for adjusting water flow rate and facilitating servicing.
- e) The external water pump and its controller cabinet need to be installed on site; the main engine provides 230V~ control signal to realize the linkage of the unit and the water pump. A stand-by pump shall be installed on the site in case that the pump in common use would break down and affect the unit operation;
- f) The water filter included the unit shall be installed on the inlet pipe of each unit to prevent the cooler from large particles entering, which could cause damage to the evaporator.
- g) A water filter of no less than 60 mesh per inch shall be installed on the inlet pipe of the external water pump to guarantee reliable operation of the water pump.
- h) At least one vent valve should be installed at the highest points in the chilled water pipeline to allow any trapped air to be exhausted. It can avoid generating cavitation noise and damaging the water pump.
- i) Auto-supply valve shall be installed for closed type of water system (without open expansion tank) in case that the unit could not operate normally when the system is short of water. It is suggested to set the outlet water pressure of the auto-supply valve 0.3bar higher than the static pressure of the system, but the set value shall be lower than the supplementing water pressure (the source of the water supplementing), or it would not conduct normal water supplement. The auto-supply valve is usually installed at the return water line of the system; heat isolation measures shall be conducted to the water supplement pipeline and water supply valve to against freeze-up in winter.
- j) The chilled water lines that are exposed to ambient

should be wrapped with supplemental heater cable and insulated to protect against freeze-up during low ambient periods, and to prevent formation of condensation on lines in warm humid locations. Vent valves and drain valves do not need heat isolation for the convenience of maintenance

k) The inlet minimal pressure of water pump shall reach 20kPa to avoid cavitation noise and damage of water pump due to cavitation.

l) It is recommended that a suitably sized by-pass and valve arrangement shall be installed to allow flushing of the pipework system. The by-pass can be used during maintenance to isolate the cooler without disrupting flow to other units.

m) Drain connections should be provided at all low points to permit complete drainage of the cooler and system water piping during low ambient temperature period and the unit would not be used with a long time. Unit power should be left switched on to provide the freeze protection function unless the liquid systems have been drained. Also unit power should be left switched off to avoid unit failure by auto starting for the freeze protection function while the liquid systems have been drained.

n) The fan coil in the water system shall be equipped with a three-way valve or a by-pass valve to make the water system circulate fluently during the period when anti-freezing water pump is operating in winter.

o) For module application, a place for thermometer sensor shall be retained on the main outlet pipe of the water system so that the leaving water temperature sensor can be installed.

p) A chilled water flow switch is already installed in the leaving water piping of the cooler. If the units are modularized, it is recommended to install another flow switch in main liquid leaving pipe.



***The Flow Switch MUST NOT be used to start and stop the unit (i.e. starting and stopping the chilled water pump). It is intended only as a safety switch.***



***Quality of the chilled water should comply with the requirement in chilled water requirement in SECTION 5. No air will be permitted in water system.***

Piping specification	Thread specification							
	G3/4	G1	G1-1/4	G1-1/2	G2	G2-1/2	G3	G4
Specification of galvanized steel pipes	DN20	DN25	DN32	DN40	DN50	DN65	DN80	DN100
Outer diameters of galvanized steel pipes (mm)	27	34	42	48	60	76	89	114
Specification of PP-R pipes	D25	D32	D40	D50	D63	D75	D90	D110
Outer diameters of PP-R pipes (mm)	25	32	40	50	63	75	90	110

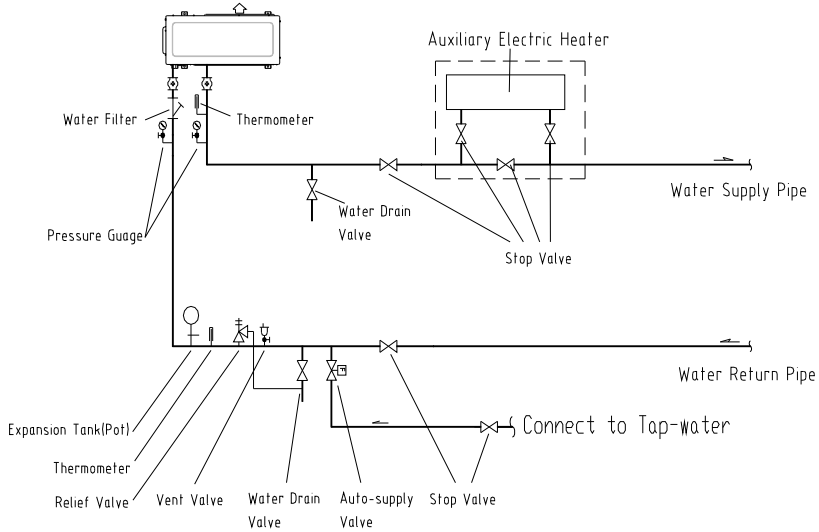
TABLE 4 – PIPE LINES SPECIFICATIONS



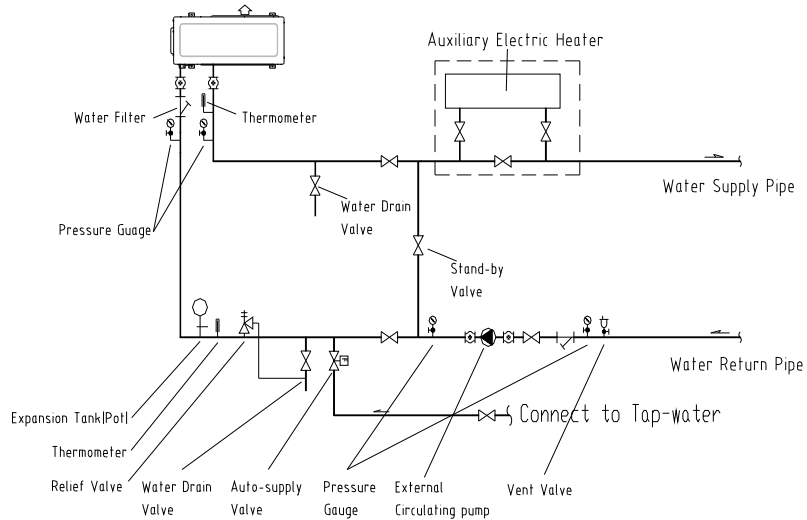
**Water system Pipework arrangement**

The following are suggested pipework arrangements for single unit with built-in pump installations. For multiple unit installations, each unit should be piped as shown.

**Chilled water system for single unit**



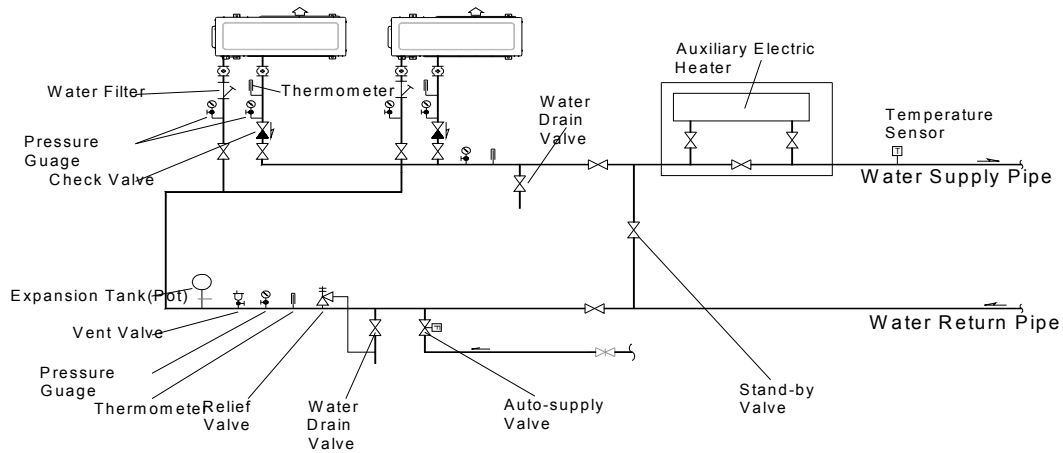
**FIGURE 9 – SINGLE UNIT SYSTEM (WITHOUT EXTERNAL PUMP)**



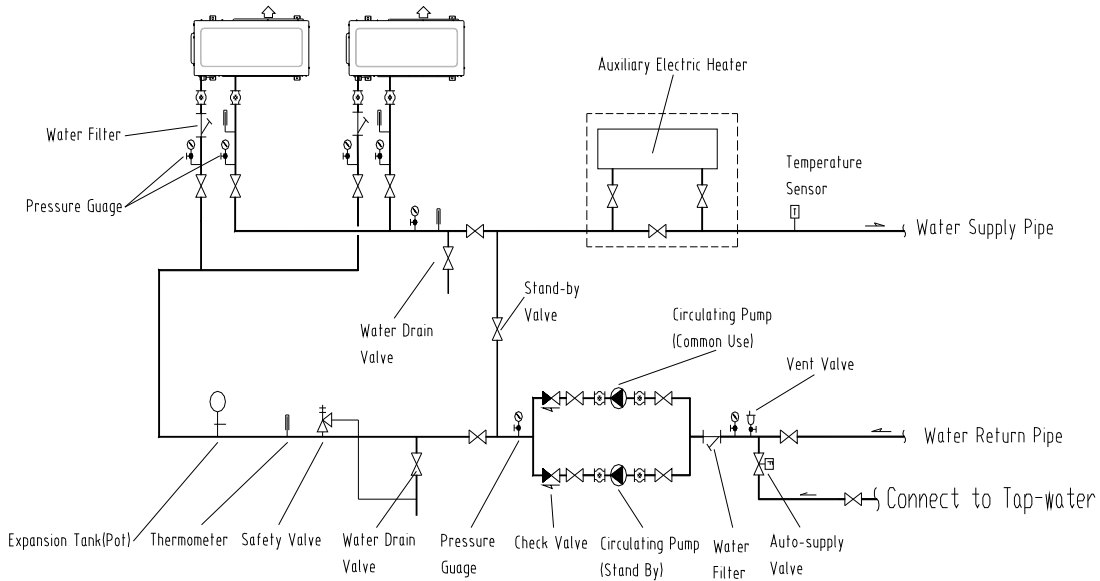
**FIGURE 10 – SINGLE UNIT SYSTEM (WITH EXTERNAL PUMP)**

**Notes:** Parts in the dotted box are optional components, and if the site does not need installation, the pipeline here can be directly connected

**Chilled water system for modular unit**



**FIGURE 11 – MODULAR UNIT SYSTEM (WITHOUT EXTERNAL PUMP)**



**FIGURE 12 – MODULAR UNIT SYSTEM (WITH EXTERNAL PUMP)**

**Notes:**

1. Parts in the dotted box are optional components, and if the site does not need installation, the pipeline here can be directly connected.
2. In modular connection, considering the balance of water pressure drop and water flow rate, the same route design should be applied. If pipelines could not be installed in the same route due to the limitation of installation space, please contact the local JCI office for confirmation.
3. In modular connection system with external water pump, the standby water pump is not necessary; but the standby water pump is recommended to be included in case that the water pump in common use might break down and affect the normal use of the unit.

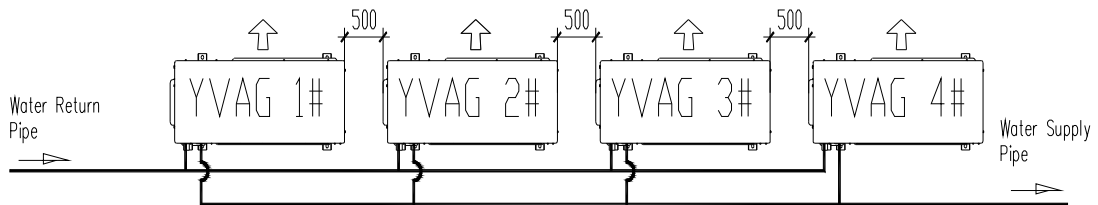
**TABLE 5- COMPONENTS SYMBOL**

Graphic Symbol	Name	Graphic Symbol	Name
	Stop Valve		Flow Switch
	Pressure Gauge		Temperature Sensor
	Thermometer		Vent Valve
	Water Pump		Safety Valve
	Metal flexible joint		Check Valve
	Y Type Fliter		Pressure Differential Valve
	Ball Valve		Pressure Differential controller
	Auto-supply Valve		

**Modular Connections**

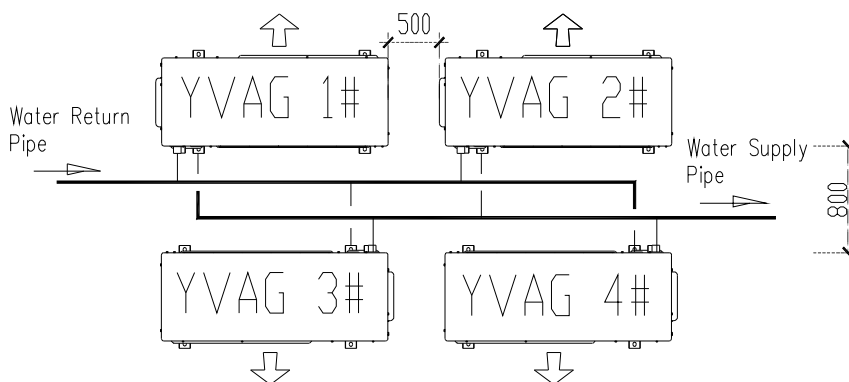
The units are able to be connected in a pipe network for centralized control. The control system is designed to work effectively within a maximum of 4 control boards (communication addresses) connected. Follow the arrangements below for side by side and back by back layout.

**Side by Side Layout**



**FIGURE 13 – SIDE BY SIDE LAYOUT**

**Back By Back Layout**



**FIGURE 14 – BACK BY BACK LAYOUT**

**Notes:**

1. The distances between the walls and peripheral units should employ the same rules as shown in Clearance in SECTION 5, if the units are surrounded by walls
2. Installation contractor must include vent and drain accommodations in chilled water piping near the evaporator.
3. Stop valves must be installed at the inlet of each unit to balance chilled liquid distribution.
4. A minimum interval of 700 mm must be reserved for field wiring, commissioning and maintenance.
5. Detailed dimensions refer to single unit drawings.

**System Leaving Water Temperature Sensor**

When the system is modular connection and the user chooses leaving water temperature as control method, there should be a leaving water temperature sensor installed on the main water supply pipe. The leaving water temperature sensor is connected with 1# unit. No requirement for temperature sensor installation if leaving water temperature control is not applied.

Installation methods of temperature sensor:

- a) G1/2' tee joint of internal thread is installed on the main water supply pipe.
- b) G1/2' blind tube of external thread is installed on the tee joint of internal thread.
- c) Conduction oil is injected into the blind tube, then the temperature sensor is inserted and sealed tightly with thread locks.

The blind tube should be installed in horizontal direction, perpendicular to the main pipe, in case of freeze-up in the tube.

For accuracy of temperature sensing, the sensor should be inserted at the bottom of the blind tube.

**Buffer Water Tank**

When water volume capacity for the water system is little, sharp drop of water temperature would affect defrosting when the unit is operating in heat mode for defrosting. To avoid this, buffer water tank should be applied or the diameter of main water pipe should be enlarged to meet the recommended range in the following table.

The referential installation methods for buffer water tank as shown below.

**Expansion Tank (Pot)**

There is no expansion tank as standard components built-in the unit. **When the site water system is set as a closed cycle system, Expansion Tank must be**

**installed on the return pipe of the unit.** Expansion tank should be applied when water volume capacity of water system is higher than that in the following table. Installing height of the expansion water tank should be within 50 m above the unit. The design pressure of expansion tank should be 6 bar at least.

**Water Treatment**

The declared cooling capacity of unit on nameplate or other catalogs is based on the situation that fouling factor is 0.018m<sup>2</sup>C/kW. Dirt, filth, oil or other impurities all will have a negative effect on the heat transfer efficiency and the unit performance. Foreign matters in chilled water would increase water pressure drop of the heat exchanger, reduce water flow and cause mechanical damage for pipes of heat exchanger.

Strict measurement should be carried out for water quality for the water system of unit, and water quality should conform to requirements in the table of *chiller water requirement* in TABLE 6.

PROJECT	UNIT	value	result	
			corrosion	scale
PH (25°C)		7.5-8.0	○	
S04--	ppm	<100	○	
HC03-/ S04--	ppm	>1.0	○	
Cl-	ppm	<50	○	
P04	ppm	<2.0	○	
NH3	ppm	<0.5	○	
Free Chlorine	ppm	<0.5	○	
Fe+++	ppm	<0.5	○	
Mn++	ppm	<0.05	○	
CO2	ppm	<10	○	
H2S	ppb	<50	○	
Temperature	°C	<65	○	○
Oxygen content	ppm	<0.1	○	
Total hardness	dH	4.8-8.5		○

TABLE 6- Water quality standards

Regular measurement on water quality should be conducted before unit installation and during in service, and water quality should conform to the requirements in the above table. Corrosion-related leak of heat exchanger and serious deposition may occur if water quality is over proof for long time.

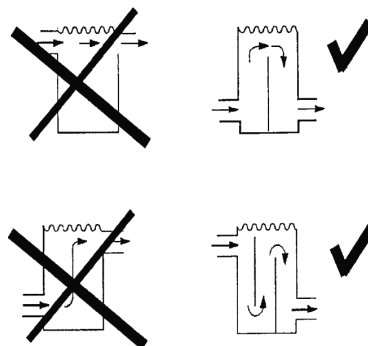


*Users shall be at their own risk for any loss if it is due to the matter of water quality.*

**TABLE 7 – WATER VOLUME LIMITATION**

Model Type	YVAG	012	014	016	018	020	022	025	028	033	040
<b>Rated Water Flow</b>	m3/h	1.9	2.4	2.7	3.1	3.4	3.8	4.3	4.8	5.5	6.9
<b>Water Volume Capacity Limitation</b>	Minimum/L	45	55	55	55	78	78	78	78	78	78
	Maximum/L	90	90	90	90	180	180	180	180	180	180
<b>Minimum Water Pressure for Operation</b>	kPa	30	30	30	30	30	30	30	30	30	30
<b>Maximum Water Pressure for Operation</b>	kPa	600	600	600	600	600	600	600	600	600	600

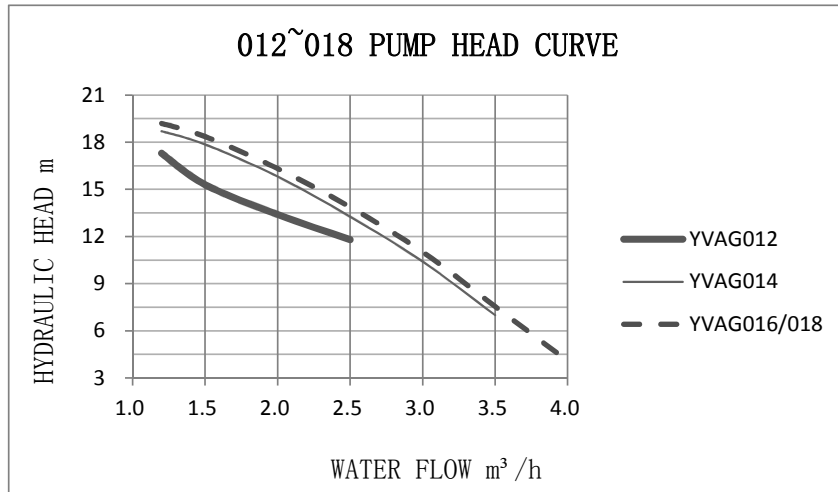
**Notes:** The data above is suitable for the condition when the highest point of water system is 20 m higher than the unit. The maximum water volume is only available to the unit with built-in expansion tank.



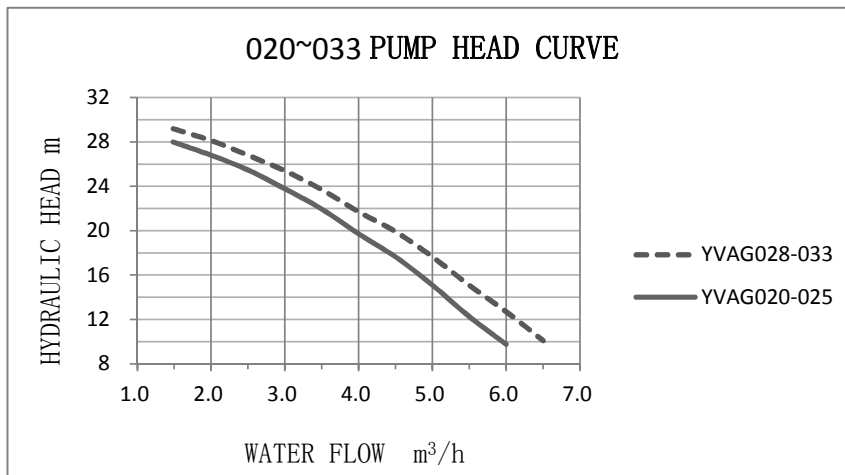
**FIGURE 15 – BUFFER WATER TANK INSTALLATION**

**UNIT EXTERNAL HEAD**

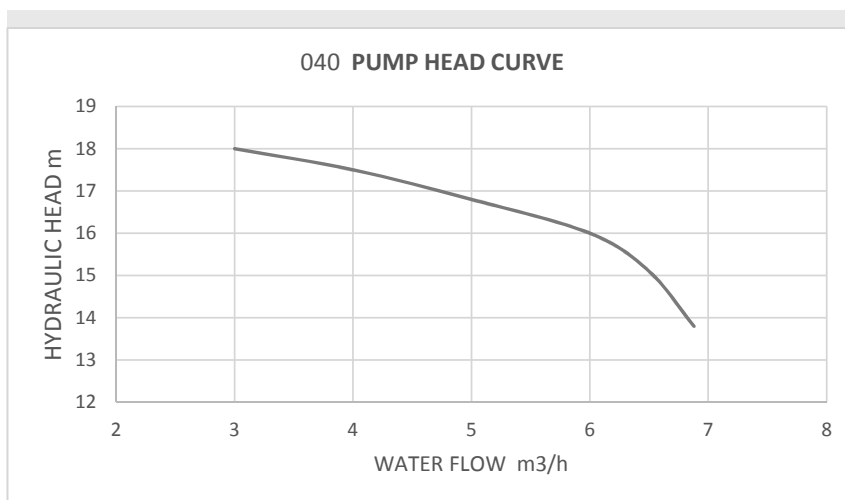
Measurement unit (contain water pump) to the inlet and outlet water pressure difference, can draw a closed head under the water, the closed to lift the water flow basic as shown in the closed pressure curve, the pipeline system design "closed pressure curve" for reference.



**FIGURE 16 – UNIT EXTERNAL HEAD CURVE (012~018)**



**FIGURE 17 – UNIT EXTERNAL HEAD CURVE (020~033)**



**FIGURE 18 – UNIT EXTERNAL HEAD CURVE (040)**

Note: without a pump unit under the rated flow resistance of 35 kPa.

## ELECTRICAL CONNECTION

The units are shipped with all factory-mounted controls wired for operation.

**Field Wiring** – Power wiring must be provided through a non-fused disconnect switch to the unit terminals in accordance with CE or local code requirements. Minimum circuit ampacity and maximum dual element fuse size are given in Electrical Data.

Only copper power wiring should be used for supplying power to the unit. This is recommended to avoid safety and reliability issues resulting from connection failure at the power connections to the unit. Aluminum wiring is not recommended due to thermal characteristics that may cause loose terminations resulting from the contraction and expansion of the wiring. Aluminum oxide may also build up at the termination causing hot spots and eventual failure.

See unit wiring diagrams for field and power wiring connections, communication wiring connections, modular wiring, alarm contactors, remote switch input, remote cooling/ heating switch, etc.

### Alarm Status Contacts

Normally-open contacts are available for each unit. These normally-open contacts remain open when the system is functioning normally. The respective contacts will close when the unit is shut down on a unit fault, or locked out on a system fault. For modular applications, the master unit will not only output internal fault, but also the fault of subordinate units. Field connections are at terminals 6 to 8.

### Remote Switch Contacts

To remotely start and stop the unit, dry contacts can be wired to terminals 2 to 4. Refer to unit wiring diagram.

The function will be available after being activated through HMI.

### Remote C/ H Switch

The contacts are used to switch unit operating mode remotely. Dry contacts can be wired to terminals 1 to 5. Refer to unit wiring diagram.

The function will be available after being activated through HMI.

## External Interlock

The unit will be allowed to run only if the interlock is connected. It is used to link external facilities like fire alarms in case there's an emergency cutoff. It is wired to terminals 3 to 4.

External interlock is short-circuited before delivery.

## Compressor Heater

Compressor heaters are standard. All compressors utilize one heaters with 20 W each.

Compressor heater will be switched on in standby mode when ambient temperature is below 12 °C. This will assure that liquid slugging and oil dilution does not damage the compressors.

## Pressure Cutout

One high pressure cutout is installed in the discharge piping of each system. The HP cutout opens at 4.03 MPa (585 PSIG) and closes at 3.1 MPa (450 PSIG).

## Safety Precautions

**Please comply strictly with the following important items related with safety in “safety precautions”**

1. The units YVAG012~040RSE can be connected only to a power supply with system impedance no more than 0.184 ohm. If necessary, please consult your supply authority for system impedance information.
2. Wire should conform to national standards, its diameter should not be lower than recommended wire diameter and its weight shall not be lighter than chloroprene rubber armored cable (No. 57 wire in IEC60245).
3. Only professionals from manufacturers, its service departments or other similar institutions can renew the broken flexible power wires for safety reasons.
4. Never share the power supply with other electric appliances in case of overload. Earth leakage circuit breaker matching with working voltage of unit should be used.
5. Only designated accessories by YORK can be used, and services of installation and technology support can be obtained from manufacturers or authorized resellers. Fail to correct installation for control accessories may cause malfunction of the controller or electric shock etc. Users are not allowed

to make any repair which may cause damage or electric shock. For any maintenance demand, please contact the manufacturer.

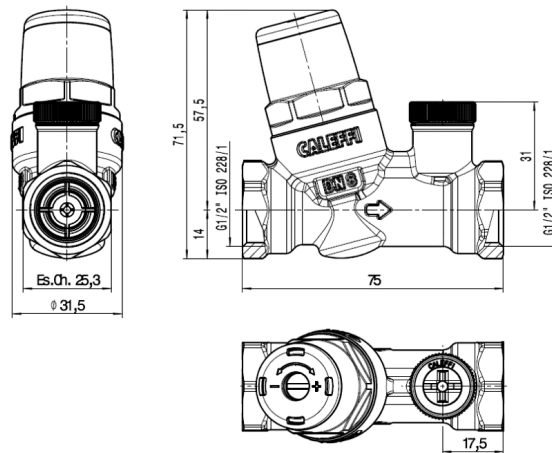
- 6. Never connect ground wire of unit power supply with that of a gas fuel pipe, water pipe, lightning arrester or telephone. Improper ground connection may cause electric shock etc. Make sure connection between ground wire and the ground terminal/the grounding electrode is normal with regular inspection.
- 7. Field wiring should avoid edges of sheet metal, sharp point of bolt, high-temperature tube pipe and compressor shell in case of wire damage.
- 8. Wire fasteners should be used in case of wires dropping out and wire damage caused by friction with other parts.
- 9. Never touch with control elements and terminal

parts other than control panel in case of personal injury as there's electricity in control cabinet before power supply is cutoff.

- 10. Never operate the wire controller with sharp materials for fear of scratching the wire controller screen. Never contort or pull out electric wires in the control cabinet to prevent loose wiring and control failure. Benzene, diluents or chemical reagent is not allowed to clean the controller and control elements to avoid corrosion or malfunction. Use cloth with neutral decontaminant solution for cleaning during which the cloth should not be too wet; then clean again with dry cloth. Never excessively press on the screen in case of allochromasia.

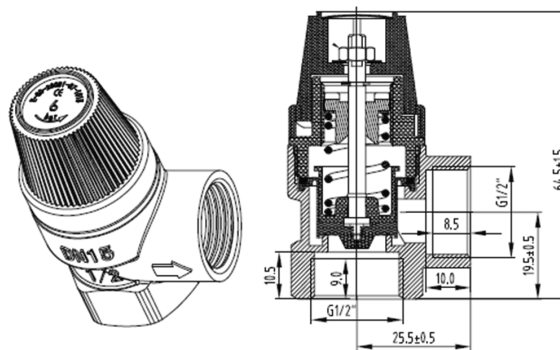
- 11. Electric wires and electronic wires should be separated during unit wiring for normal communication and operation.

**ACCESSORY DIMENSIONS**



**FIGURE 19 – AUTO-SUPPLY VALVE DIMENSION**

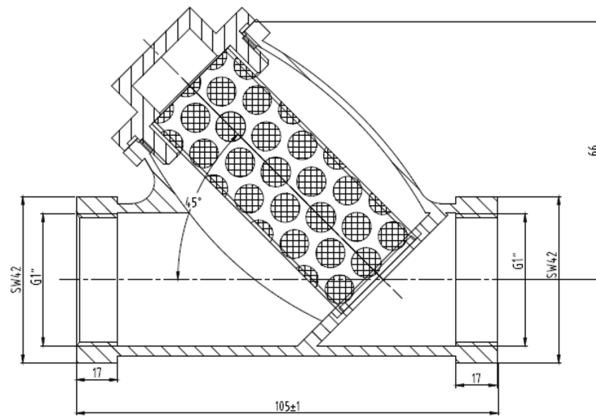
**Notes:** All dimensions are in mm unless specified otherwise



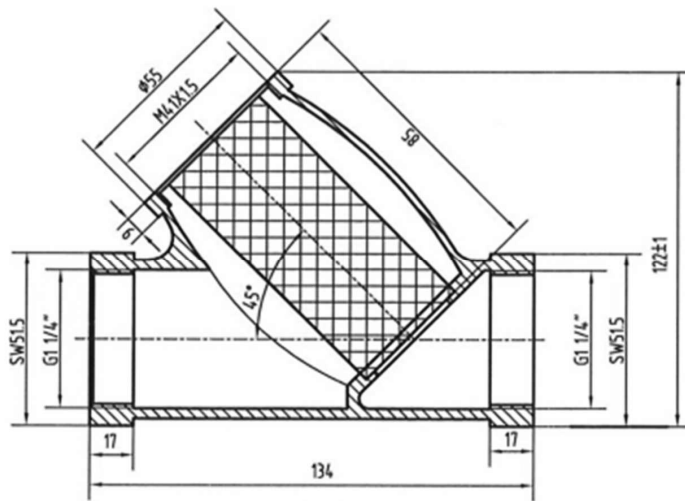
**FIGURE 20 – RELIEF VALVE DIMENSION**

**Notes:** All dimensions are in mm unless specified otherwise

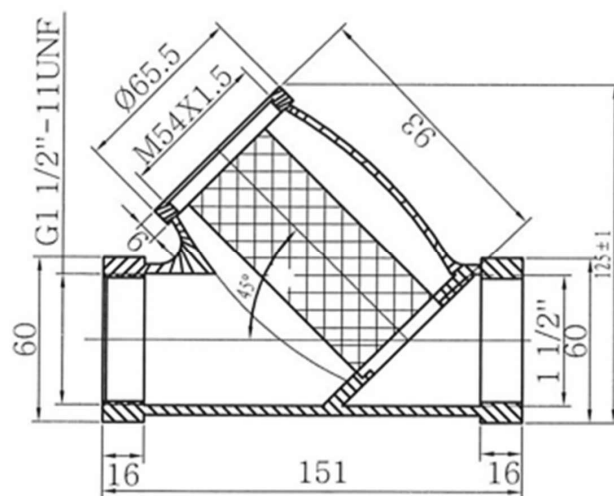




**FIGURE 21 – WATER FILTER DIMENSION (012~018)**



**FIGURE 22 – WATER FILTER DIMENSION (020~033)**



**FIGURE 23 – WATER FILTER DIMENSION (040)**

**Notes:** All dimensions are in mm unless specified otherwise

## SECTION 3 –ELECTRICAL CONTINUITY

### ELECTRICAL CONNECTION

The units are shipped with all factory-mounted controls wired for operation.

**Field Wiring** – Power wiring must be provided through a non-fused disconnect switch to the unit terminals in accordance with GB or local code requirements. Minimum circuit ampacity and maximum dual element fuse size are given in Electrical Data.

Only copper power wiring should be used for supplying power to the unit. This is recommended to avoid safety and reliability issues resulting from connection failure at the power connections to the unit. Aluminum wiring is not recommended due to thermal characteristics that may cause loose terminations resulting from the contraction and expansion of the wiring. Aluminum oxide may also build up at the termination causing hot spots and eventual failure.

See unit wiring diagrams for field and power wiring connections, communication wiring connections, modular wiring, alarm contactors, remote switch input, remote cooling/ heating switch, etc.

### Safety Precautions

**Please comply strictly with the following important items related with safety in “safety precautions”**

1. The units YVAG012~040RSE can be connected only to a power supply with system impedance no more than 0.184 ohm. If necessary, please consult your supply authority for system impedance information.
2. Wire should conform to national standards, its diameter should not be lower than recommended wire diameter and its weight shall not be lighter than chloroprene rubber armored cable (No. 57 wire in IEC60245).
3. Only professionals from manufacturers, its service departments or other similar institutions can renew the broken flexible power wires for safety reasons.
4. Never share the power supply with other electric appliances in case of overload. Earth leakage circuit

breaker matching with working voltage of unit should be used.

5. Only designated accessories by YORK can be used, and services of installation and technology support can be obtained from manufacturers or authorized resellers. Fail to correct installation for control accessories may cause malfunction of the controller or electric shock etc. Users are not allowed to make any repair which may cause damage or electric shock. For any maintenance demand, please contact the manufacturer.
6. Never connect ground wire of unit power supply with that of a gas fuel pipe, water pipe, lightning arrester or telephone. Improper ground connection may cause electric shock etc. Make sure connection between ground wire and the ground terminal/the grounding electrode is normal with regular inspection.
7. Field wiring should avoid edges of sheet metal, sharp point of bolt, high-temperature tube pipe and compressor shell in case of wire damage.
8. Wire fasteners should be used in case of wires dropping out and wire damage caused by friction with other parts.
9. Never touch with control elements and terminal parts other than control panel in case of personal injury as there's electricity in control cabinet before power supply is cutoff.
10. Never operate the wire controller with sharp materials for fear of scratching the wire controller screen. Never contort or pull out electric wires in the control cabinet to prevent loose wiring and control failure. Benzene, diluents or chemical reagent is not allowed to clean the controller and control elements to avoid corrosion or malfunction. Use cloth with neutral decontaminant solution for cleaning during which the cloth should not be too wet; then clean again with dry cloth. Never excessively press on the screen in case of allochromasia.
11. Electric wires and electronic wires should be separated during unit wiring for normal communication and operation.

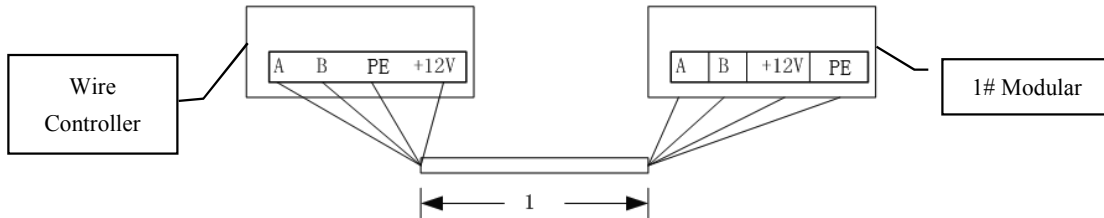
**ELECTRICAL DIAGRAM**

All electrical wiring should be carried out in accordance with local regulations. Route properly sized cables to the cable entries in the side of the unit.

It is the responsibility of the user to install over current protection devices between the supply conductors and the power supply terminals on the unit.

**Wire Controller Installation**

**STEP 1: Wiring**

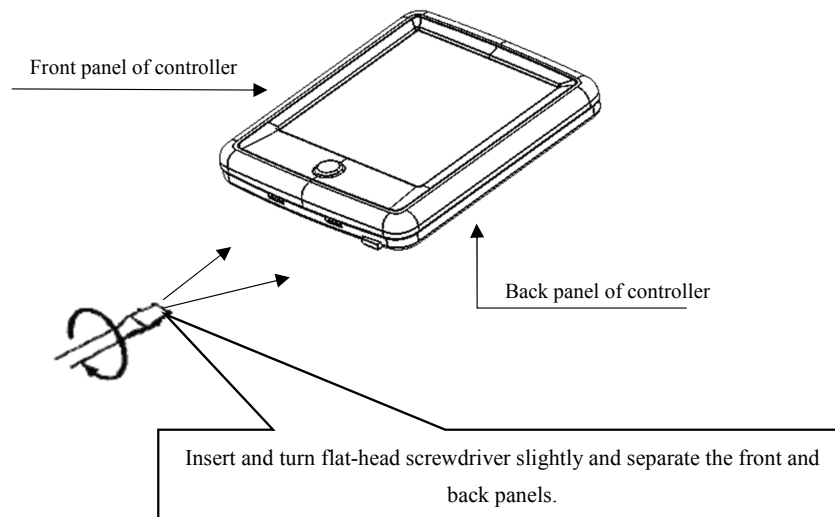


**FIGURE 24 – WIRE CONTROLLER CONNECT TO UNIT**

**Notes:**

1. Total length of communication and power supply line should be within 15m.
2. A, B, 12V, and 0V should be connected correspondingly in case of malfunction or controller damage.

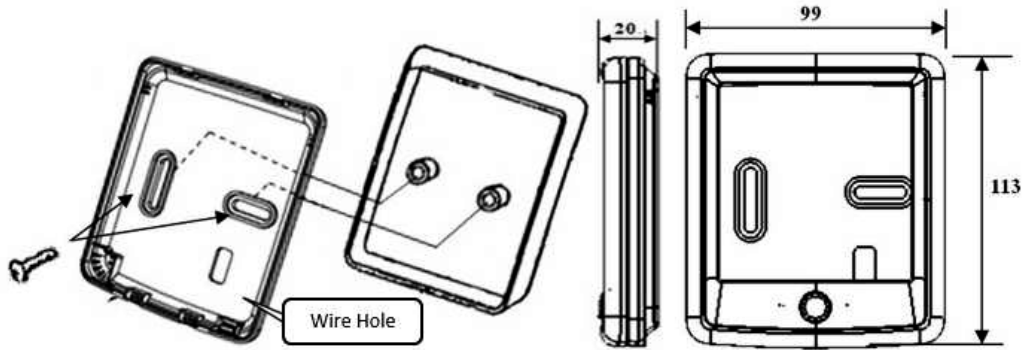
**STEP 2: Panel Disassembly**



**FIGURE 25 – WIRE CONTROLLER STRUCTURE**

**Notes:** As printed circuit board is on the front panel of controller, be cautious when using flat-head screwdriver.

**STEP 3: Back Panel Fixation**



Back panel;

Pre-embedding and installation box;

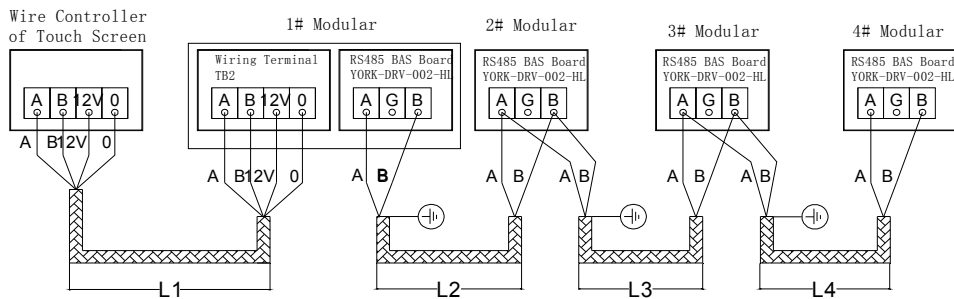
Controller size

**FIGURE 26 – BACK PANEL FIXATION**

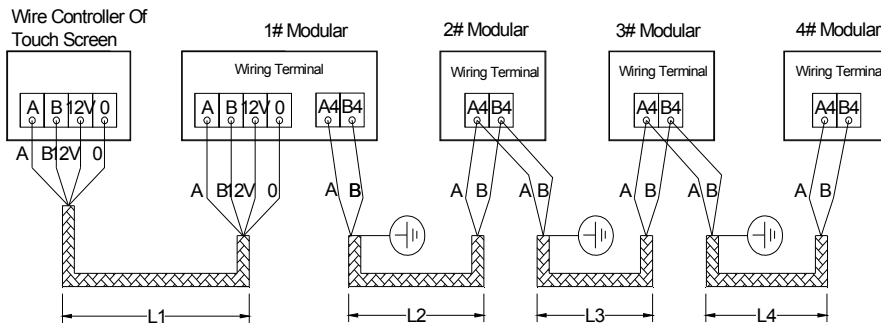
**Notes:**

1. Installed on flat surface, never excessively fasten upon the screw in case of deformation of back panel.
2. Installation box and communication cable pipe (supplied by user) from indoor unit to wire controller shall be pre-embedded. Strip off the protective film from screen slowly in case of damage.
3. Power supply should be switched off and never touch printed circuit board by hands in case of any damage while installation.

**Communication Cable Connection**



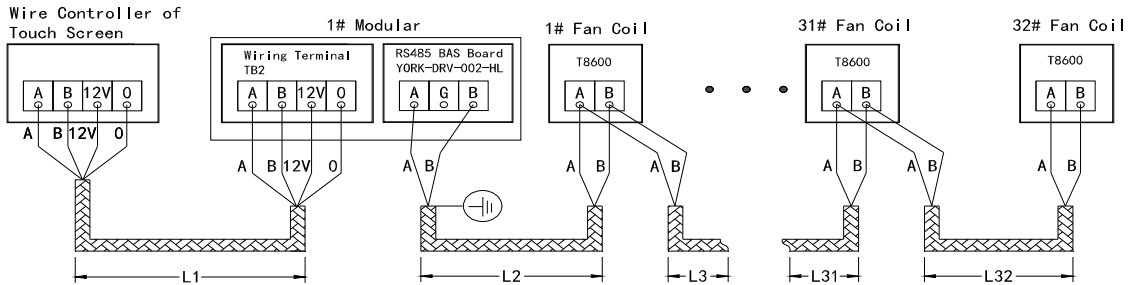
**FIGURE 27 – COMMUNICATION WIRING DIAGRAM FOR MODULAR UNIT (012~018)**



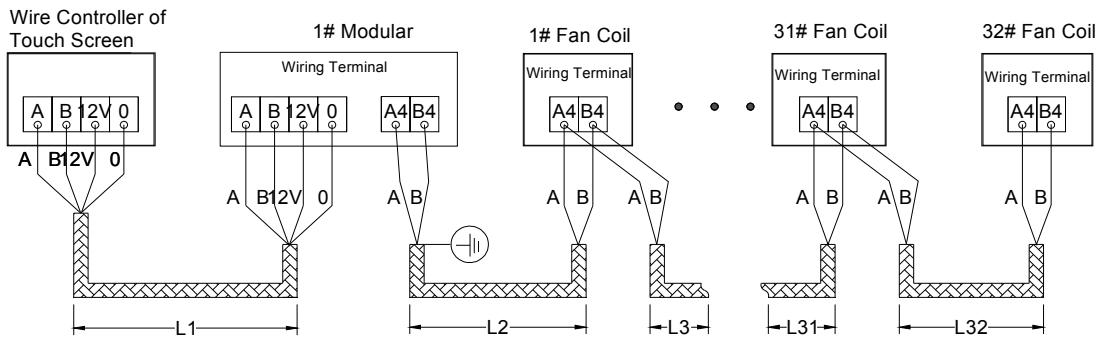
**FIGURE 28 – COMMUNICATION WIRING DIAGRAM FOR MODULAR UNIT (020~040)**

**Notes:**

1. Communication cables between host and wire controller should be 85% net type shielded wire of four-core, which length is within 15m.
2. Communication cables between units should be 85% net type shielded wire of two-core, specifications and length are as following table.



**FIGURE 29 – COMMUNICATION WIRING DIAGRAM FOR FAN COIL CONTROL (012~018)**



**FIGURE 30– COMMUNICATION WIRING DIAGRAM FOR FAN COIL CONTROL (020~040)**

**Notes:**

1. Communication cables between host and wire controller should be 85% net type shielded wire of four-core, which length is within 15m.
2. Communication cables between units and fan coils should be 85% net type shielded wire of two-core, specifications and length are as following table

**TABLE 8– COMMUNICATION CABLE SPECIFICATION**

Total length of communication cable (from wire controller to the last unit)	L=L1+L2+L3+L4+.....+L32 (Unit: m)	
	L < 100 m	100 m < L < 500 m
Model of communication line	RVSP2×0.75mm <sup>2</sup>	RVSP2×1.0mm <sup>2</sup>

**Notes:**

1. All the communication cables should be equipped on site as per the above requirement, and any inconformity should be submitted to YORK Company for confirmation in case of unit malfunction.
2. Modular connection and fan coil joint control cannot be applied simultaneously

**Unit Power Supply**

**1. Unit Power Supply**

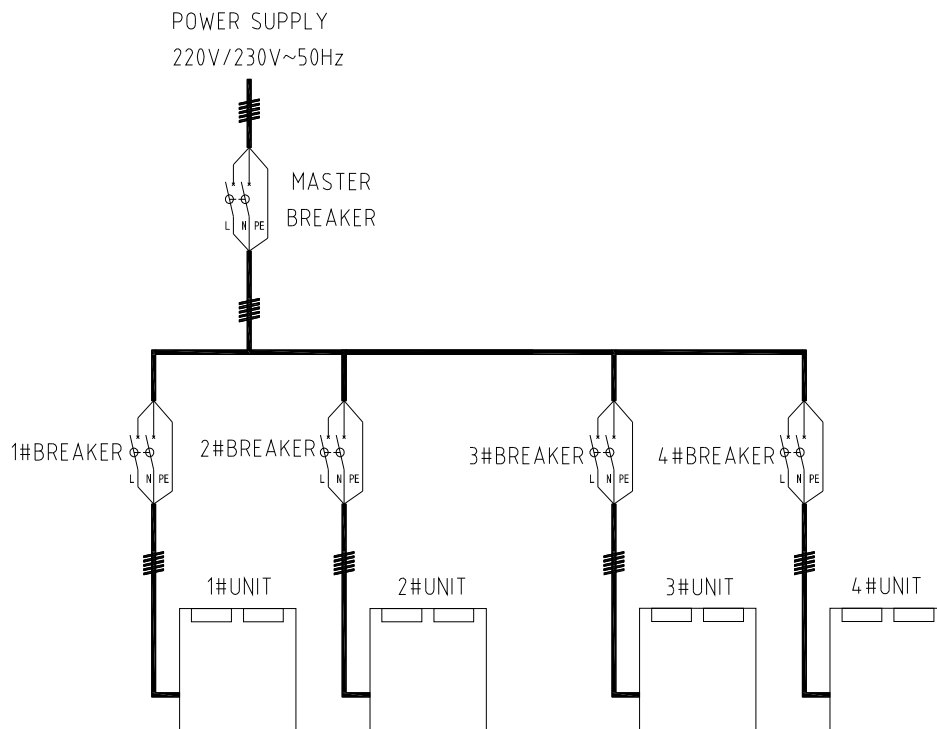
**TABLE 9 – POWER SUPPLY CABLE SPECIFICATION**

MODEL TYPE	012	014	016	018	020/022	025	028/033	040
POWER SUPPLY	220V~50Hz				380V /400V 3N~50Hz			
MAXIMUM OPERATING CURRENT	24A	33A	33A	36A	17A	19A	21A	29A
RECOMMENDED WIRE DIAMETER	4mm <sup>2</sup>	6mm <sup>2</sup>	6mm <sup>2</sup>	6mm <sup>2</sup>	4mm <sup>2</sup>	6mm <sup>2</sup>	6mm <sup>2</sup>	6mm <sup>2</sup>
RECOMMENDED BREAKER (EARTH LEAKAGE PROTECTOR)	C 型 32A 2P	C 型 40A 2P	C 型 40A 2P	C 型 50A 2P	C 型 25A 4P	C 型 25A 4P	C 型 32A 4P	CD 型 40A 4P

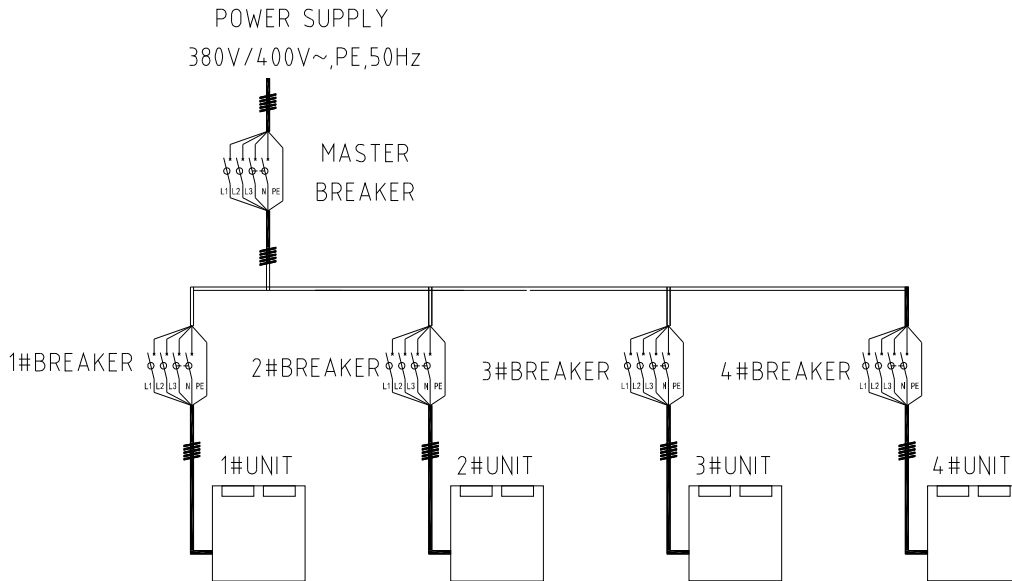
**Notes:**

1. Cable selection specification above is suitable for the conditions where ambient temperature is under 40°C, local regulations should be referred to for practice.
2. **Leakage protector must be deployed, and reliable ground connection should be conducted on site.**
3. For any discrepancy on site, like capacitance decreasing, refer to IEC standards and requirements by cable manufacturers for selection.
4. Only copper conductor can be applied as power supply cable and ZR-RVV type cable is recommended.

**2. System Power Supply Distribution**



**FIGURE 31 – SYSTEM POWER SUPPLY DISTRIBUTION DIAGRAM (012~018)**

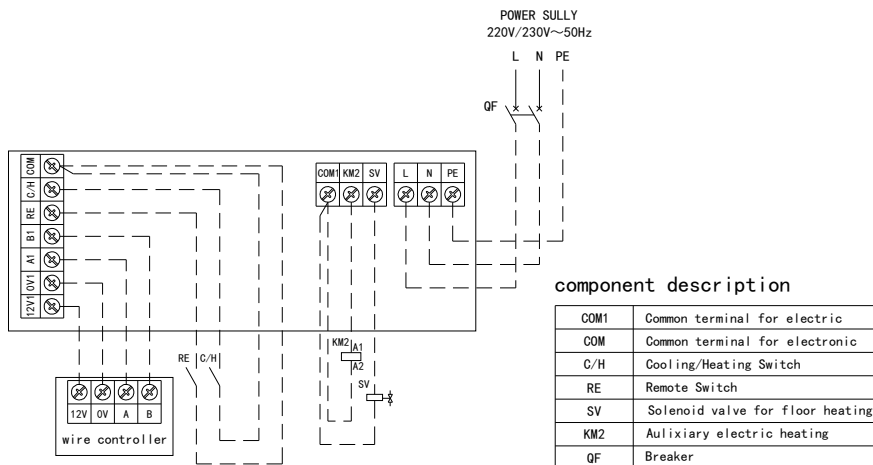


**FIGURE 32– SYSTEM POWER SUPPLY DISTRIBUTION DIAGRAM (020~040)**

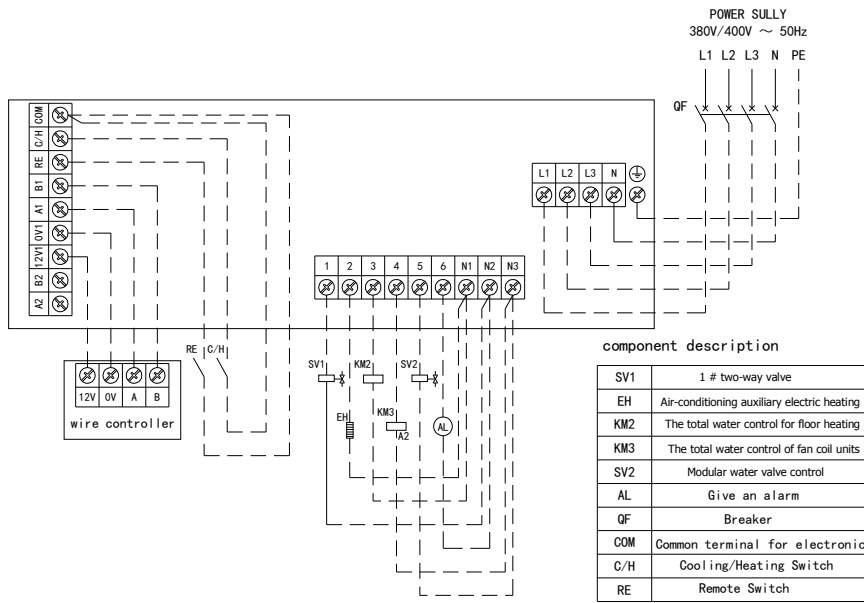
**Notes:**

1. User is responsible for providing breakers (Including master breaker).
2. Modular system with more than 4 units will not be permitted.
3. Specifications of the master breaker and the power supply cable need to be selected according to the total load. Please contact YORK service personnel for professional support.
4. This manual for the requirement of user power supply voltage: 012 ~ 018 units for 220 V and 230 V, 020 ~ 040 units for 380 V and 400 V.

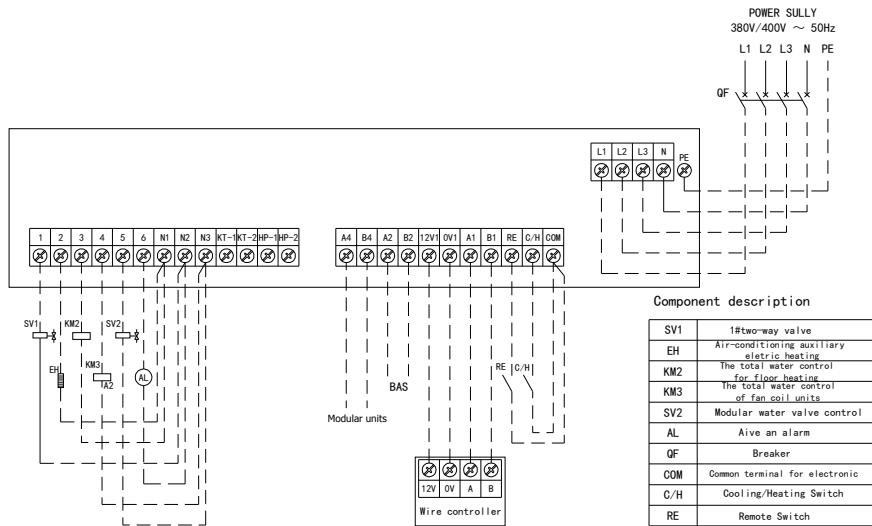
**3. Single Unit Wire Diagram**



**FIGURE 33 – SINGLE UNIT POWER SUPPLY CONNECTION (012~018)**



**FIGURE 34 – SINGLE UNIT POWER SUPPLY CONNECTION (020~033)**



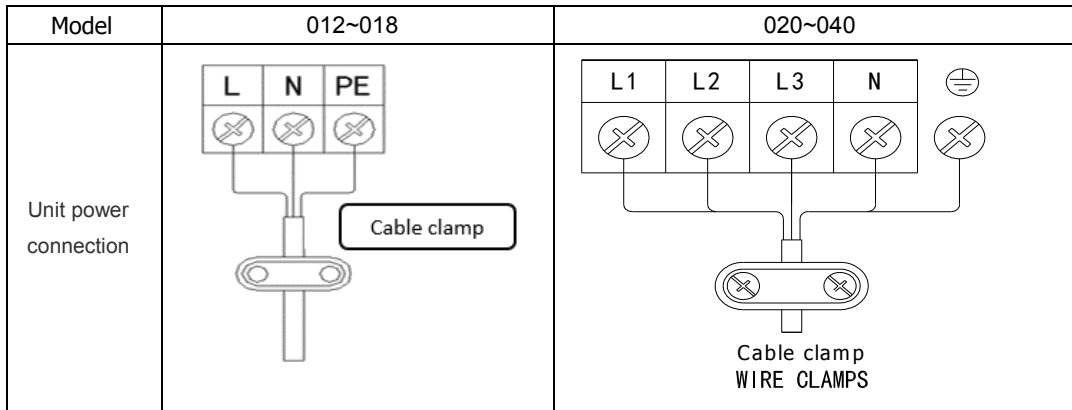
**FIGURE 35 – SINGLE UNIT POWER SUPPLY CONNECTION (040)**

**Notes:**

1. Terminal blocks of the power supply should be circular terminals, while other control signal can be connected with U shape terminals.
2. Wiring shall be performed according to the tag number on the terminals.
3. Use power supply cables of OT5.5-6 end socket with insulating sheath to connect to the power supply terminals.
4. Please apply RV0.5mm<sup>2</sup> wire for external interlocking, remote switch and cooling/heating switch installation.
5. Auxiliary electric heater of water system, alarm and solenoid valve for floor heating need to be provided by user.
6. The cable diameter of auxiliary electric heater is decided by the power output of the auxiliary electric heater; the coils of alarms, contactors and solenoid valves for floor heating can apply RV0.5mm<sup>2</sup> wire.



7. In modular system, wirings of external interlocking, remote switch, cooling/heating switch, auxiliary electric heater and solenoid valve for floor heating are all connected to the 1# modular.
8. 012 ~ 018 unit can meet the power input voltage is 220 v and 230 v under the conditions of use, 020 ~ 040unit can meet the power input voltage is 380 v and 400 v under the conditions of use



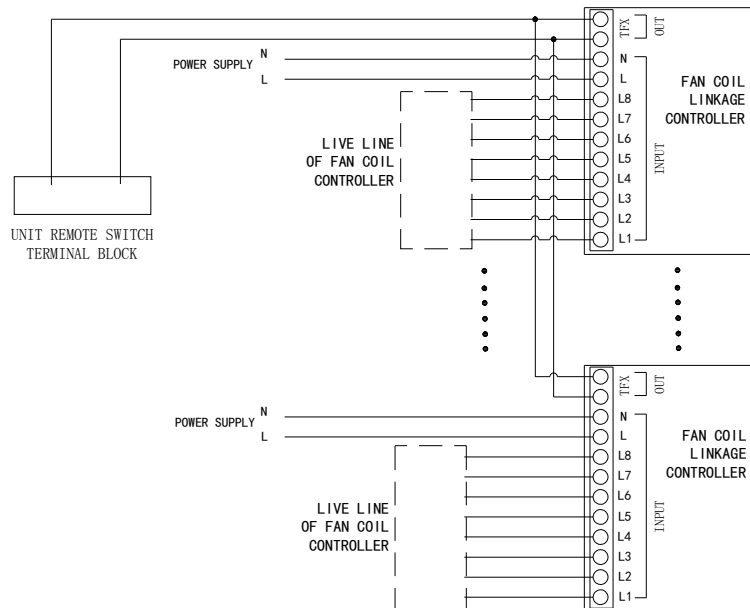
**FIGURE 36 – UNIT POWER SUPPLY TERMINAL BLOCK**

**Notes:**

1. All the user’s cable termination shall be pressure welded with copper terminals.
2. Directly intertwine the cable on the binding post is strictly forbidden.

**Air Side Terminal Connect**

If the user need to operate the unit through solenoid valve connection point of the fan coil (floor heating) controller, a fan coil linkage controller (as option) is necessary to be added. The wiring schematic diagram is shown below:



**FIGURE 37 – FAN COIL LINKAGE CONTROLLER WIRING**

**Notes:**

1. Live line of fan coil (floor heating) controller means the control line which controls a two-way or three-way valve (normally closed type), and the fan coil linkage controller need to be connected with another power supply.
2. All the controller of air side terminals need to be connected to the fan coil linkage controller.
3. A single fan coil linkage controller can be connected with 8 temperature controllers at most.
4. Fan coil linkage controllers can be in modular connection

ELECTRICAL SCHEMATIC DIAGRAM

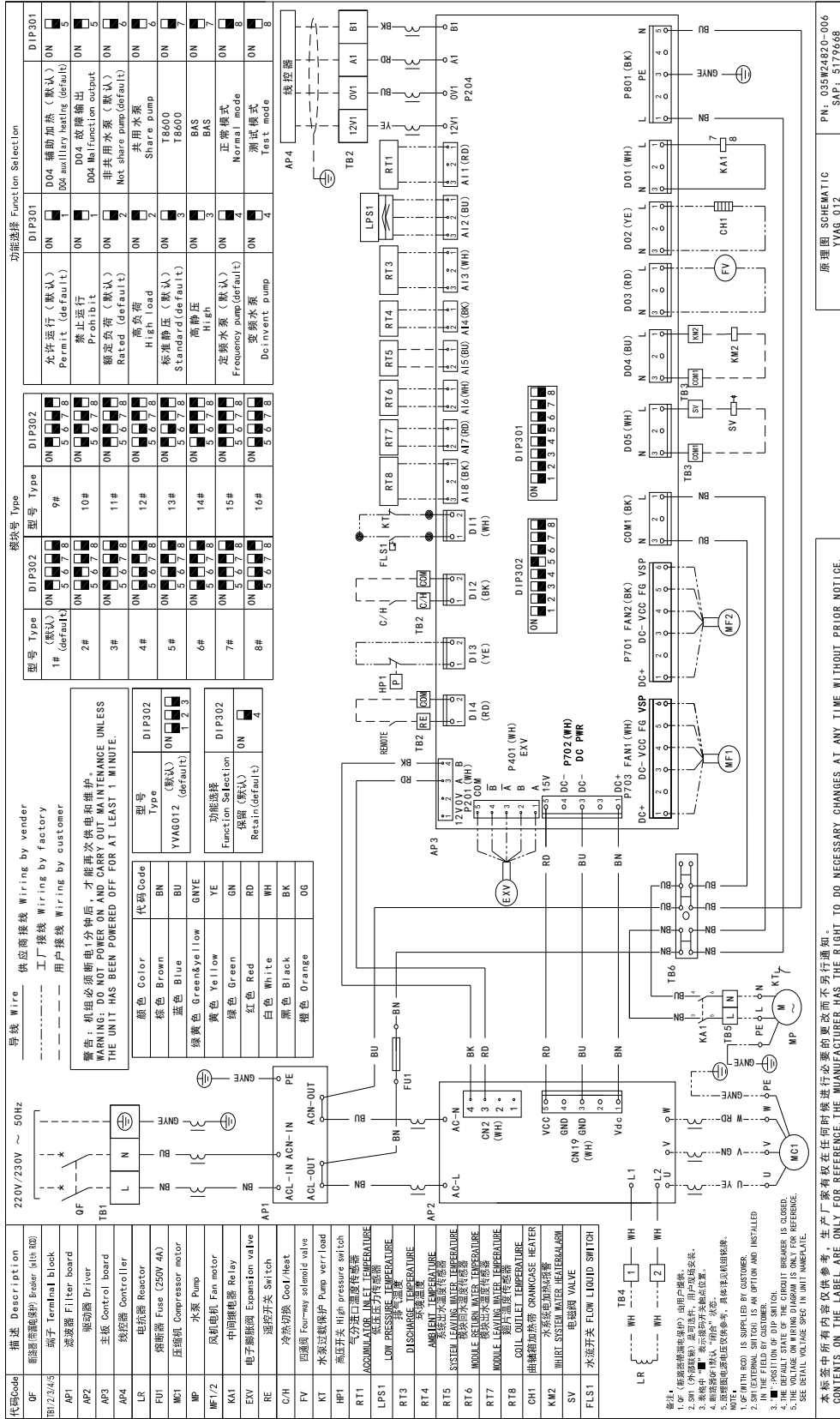


FIGURE 38 – YVAG012R ELECTRICAL SCHEMATIC DIAGRAM

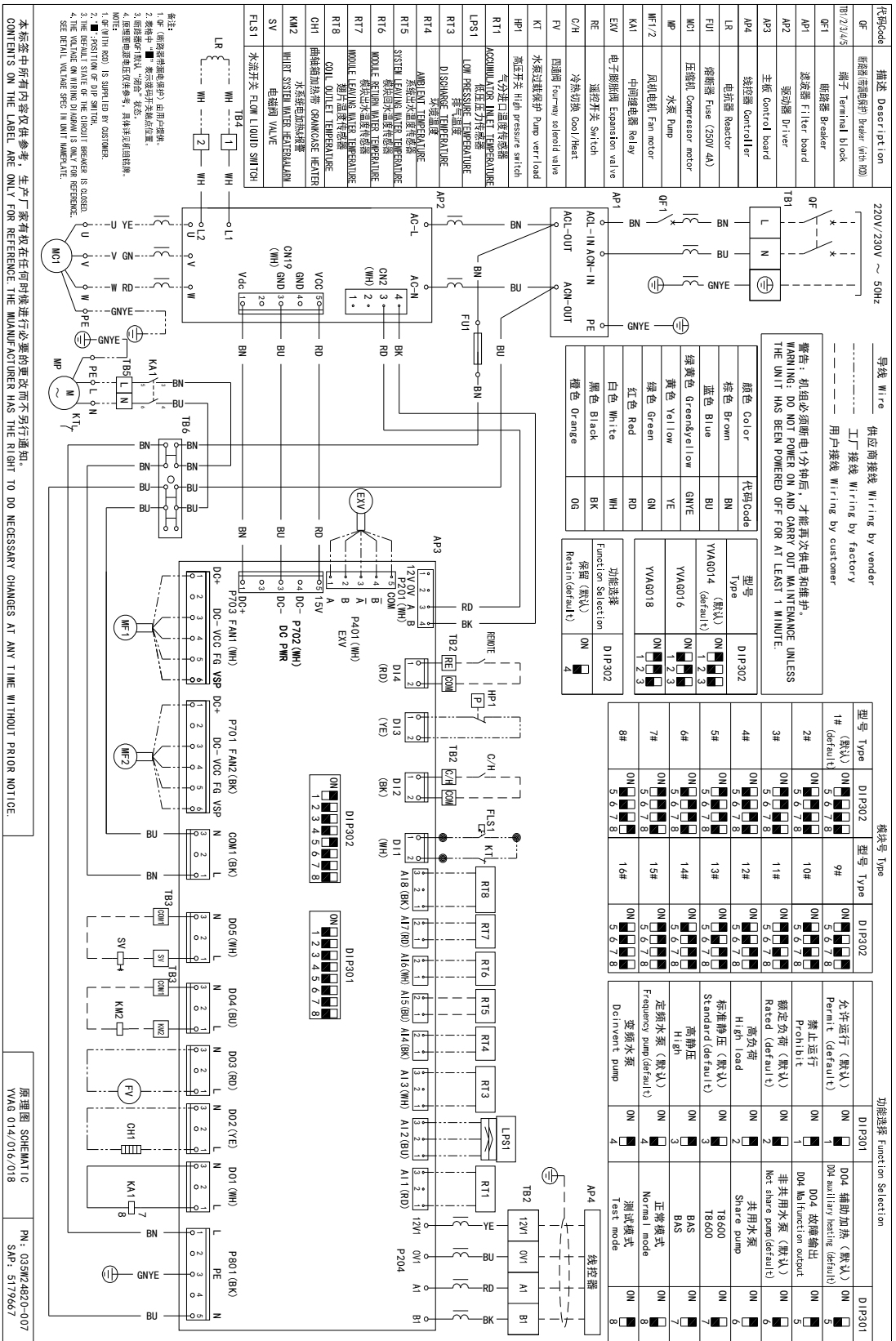
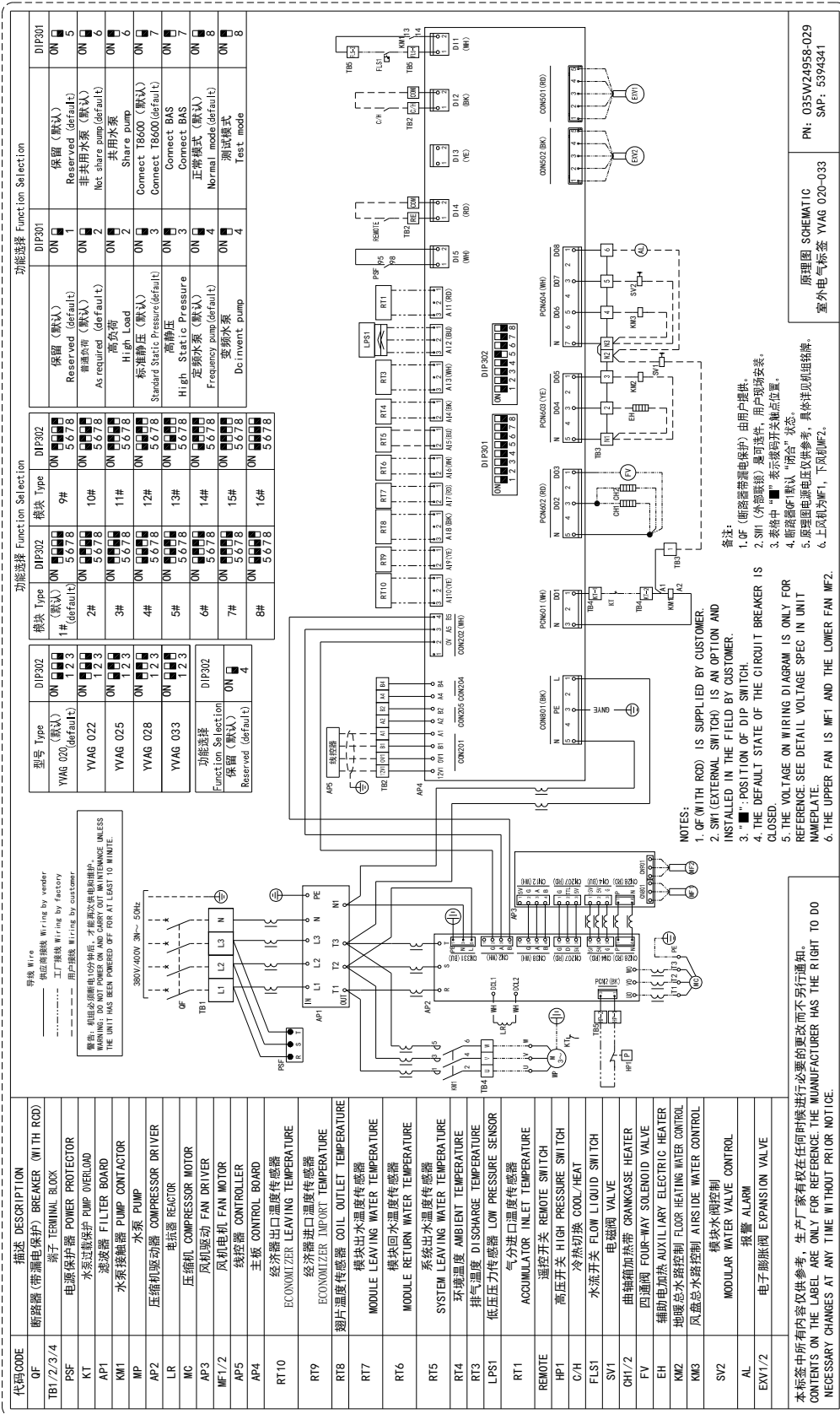


FIGURE 39 - VVAG014/016/018R ELECTRICAL SCHEMATIC DIAGRAM

本图集中所有内容仅供参考。生产厂家有权在任何时候进行必要的更改而不另行通知。  
CONTENTS ON THE LABEL ARE ONLY FOR REFERENCE. THE MANUFACTURER HAS THE RIGHT TO DO NECESSARY CHANGES AT ANY TIME WITHOUT PRIOR NOTICE.

原理图 SCHEMATIC  
VVAG 014/016/018  
PH: 035W2420-007  
SP: 5179667



原电路图 SCHEMATIC  
室外电气标签 YVAG 020-033  
PH: 035W24958-029  
SAP: 5394341

本标志书所有内容仅供参考，生产厂家有权在任何时候进行必要的更改而不另行通知。  
CONTENTS ON THE LABEL ARE ONLY FOR REFERENCE. THE MANUFACTURER HAS THE RIGHT TO DO  
NECESSARY CHANGES AT ANY TIME WITHOUT PRIOR NOTICE.

**FIGURE 40- YVAG020~033 ELECTRICAL SCHEMATIC DIAGRAM**



## SECTION 4 – WIRE CONTROLLER OPERATION



*Don't touch the screen with sharp points or edges which may damage the controller. Don't twist or pull the wires of the controller. Don't wipe the controller with benzene, diluent or chemical cloth. Otherwise discoloration or mechanical failure may occur. To remove dirt, dip the cloth in the water with a neutral detergent and wring the water before cleaning. Wipe dry the controller with dry cloth. Do not exert excessive force on the display or connection in order to avoid changes in hue.*

### INTRODUCTION

The touch screen wire controller is standard optional for remote controls of YVAG units. The functions of parameter setting, operating status viewing and fault recording are available. Instead of describing the information above, the wire controller utilizes graphic icons in user interface.

### INTERFACE



Area 1: Date and time display;

Area 2: Timer display;

Area 3: Temperature display (include the set point and actual controlled water temperature);

Area 4: Serial number display;













Area 5: Operating mode setting;

Area 6: Running status display;

Area 7: Touch-keys.

The meanings of the icons are listed in Table 21.

**TABLE 10 – FUNCTIONS OF KEYS**

KEY	MEANING	KEY	MEANING	KEY	MEANING
	COOLING		FUNCTION		FAULT
	HEATING		TIMER		PUMP
	CONFIRM		UP		LOCK
	CANCEL		DOWN		LOW SOUND

**BASIC OPERATIONS**

**Start and Stop the Unit**

Press the button below on the screen to start or stop the unit.



**Operating Mode**

Press the key of “COOLING” or “HEATING” to set or switch operating modes. The “SET” icon will be showing during the process. Press “CONFIRM” to finish the setting, or the controller will automatically save if there’s no operation for 10 seconds. Press “CANCEL” to abandon the setting.

**Liquid Temperature Setpoint**

Press “UP” or “DOWN” key in daily display screen to set target liquid temperatures. Press “CONFIRM” to finish the setting, or the controller will automatically save if there’s no operation for 10 seconds. Press “CANCEL” to abandon the setting.

**ADVANCED OPERATIONS**

**Date and Time**

Press the “TIMER” and “FUNCTION” keys simultaneously for 5 seconds to enter the Date and Time setting screen. The “TIMER” and “SET” icons will flicker while the function is activated.

Press “TIMER” to toggle between Year, Month, Day, Hour and Minute. Press “UP” and “DOWN” icons to modify the values. Touch and hold the icons to increase or decrease the values by 5 each time.

Press “CONFIRM” to save the value and auto switch to the next setting. Press “TIMER” to cancel the operation



and auto switch to the next setting.

The setting will terminate if there's no operation for 5 seconds or "CANCEL" is pressed.

### Schedule Timer

Press the "TIMER" key for 5 seconds to enter Schedule Timer setting screen. The "TIMER", "SET" and "ON" icons will flicker while the function is activated.

The Schedule Timer will toggle between Timer ON, Timer OFF and Timer Mode.

Press "FUNCTION" to select Hour and Minute which are able to be set by "UP" and "DOWN" keys. Once the setting is finished, press "CONFIRM" to save the value and auto switch to the next setting. Press "TIMER" to cancel the operation and auto switch to the next setting.

In Timer Mode setting, press "FUNCTION" to switch the modes between ONCE, DAILY and WEEKLY. Press "CONFIRM" to save the value and auto switch to the next setting. Press "TIMER" to cancel the operation and auto switch to the next setting.

In WEEKLY timer setting, the weekdays are able to be switched over by pressing "FUNCTION" key. Press "UP" to "CONFIRM" the weekday timer activation and move on to the next weekday. Press "DOWN" to cancel the activation of the weekday and move on to the next.

The Schedule Timer setting will terminate if there's no operation for 5 seconds or "CANCEL" is pressed.

### Parameter Setting

Press the "FUNCTION" key in daily display for 5 seconds to enter System Parameter Setting screen. Repeat the operation to enter Module Parameter Setting screen. The "LOCK" icon will appear while the function is activated.

In System Parameter Setting, the parameters will be displayed in hour display area (Area 1) in sequence by pressing "FUNCTION" key.

In Module Parameter Setting, the modules can be switched over by pressing "TIMER" key.

Press "UP" or "DOWN" to set the value and press "CONFIRM" to save the value. The setting will terminate if there's no operation for 5 seconds or "CANCEL" is pressed.

### Fault Diagnosis

Press "FUNCTION" and "CANCEL" keys for 5 seconds to enter Fault Diagnosis. The "FAULT" icon will appear while the function is activated.

The fault codes will be displayed in temperature display area (Area 3) with time recorded. The serial number of the module will be displayed as 10-bit of Area 4.

Press "UP" and "DOWN" for more fault information. A maximum of 16 faults can be recorded.

The setting will terminate if there's no operation for 5 seconds or "CANCEL" is pressed.

**TABLE 11 – DESCRIPTION OF FAULT CODE (012~018)**

DESCRIPTION	FAULT CODE
AI1 Refrigerant inlet accumulator temperature sensor fault	1A
AI2 Suction pressure transducer fault	2A
AI3 Discharge temperature sensor fault	3A
AI4 Ambient temperature sensor fault	4A
AI5 System leaving water temperature sensor fault	5A
AI6 System return water temperature sensor fault	6A

AI7 Unit leaving water temperature sensor fault	7A
AI8 Coil temperature sensor fault	8A
DI1 Water flow switch fault or water pump overload alarm	1d
DI3 Over pressure alarm	3d
Communication failure ( failure on 1# unit is between principal unit and wire controller while others for principal and subordinate unit. )	1E
Conflict setting of unit model type	2E
Excessive lower ambient temperature for cooling mode	4E
Excessive lower system leaving water temperature for cooling mode	6E
Excessive higher system leaving water temperature for heating mode	7E
Communication failure between principal unit and T8600 or BAS	9E
Freezing protection in winter	10E
Excessive lower unit leaving water temperature for cooling mode	11E
Excessive higher unit leaving water temperature for heating mode	13E
Excessive lower unit leaving water temperature for heating mode	15E
Excessive higher discharge temperature	1F
Freezing protection of BPHE	9F
Communication failure of unit ( between Microboard and driver )	2p
Mismatching of driver type	4p
Compressor driver alarm	6p
Excessive higher speed of fan 1	8p
Excessive higher speed of fan 2	9p
Excessive lower speed of fan 1	10p
Excessive lower speed of fan 2	11p
Microboard hardware failure	14p
Driver hardware overcurrent	101
Compressor driving failure	102
Compressor overcurrent	103
Reserved	104
Sampling failure of compressor current	105
Heat sink/IPM overheating alarm	106
Pre-charge failure	107
DC bus over voltage	108
DC bus under voltage	109
AC input under voltage	110
AC input overcurrent	111
Driver check out failure	112
AC input hardware overcurrent	113
Driver temperature sensor fault	114

**TABLE 12– DESCRIPTION OF FAULT CODE (020~040)**

DESCRIPTION	FAULT CODE
AI1 Refrigerant inlet accumulator temperature sensor fault	1A
AI2 Suction pressure transducer fault	2A
AI3 Discharge temperature sensor fault	3A
AI4 Ambient temperature sensor fault	4A
AI5 System leaving water temperature sensor fault	5A
AI6 System return water temperature sensor fault	6A
AI7 Unit leaving water temperature sensor fault	7A
AI8 Coil temperature sensor fault	8A
AI9 Economizer inlet temperature sensor fault	9A
AI10 Economizer outlet temperature sensor fault	10A
DI1 Water flow switch fault or water pump overload alarm	1d
DI3 Over pressure alarm	3d
DI5 Power failure	5d
Communication failure ( failure on 1# unit is between principal unit and wire controller while others for principal and subordinate unit. )	1E
Conflict setting of unit model type	2E
Excessive lower ambient temperature for cooling mode	4E
Excessive lower system leaving water temperature for cooling mode	6E
Excessive higher system leaving water temperature for heating mode	7E
Communication failure between principal unit and T8600 or BAS	9E
Freezing protection in winter	10E
Excessive lower unit leaving water temperature for cooling mode	11E
Excessive higher unit leaving water temperature for heating mode	13E
Excessive lower unit leaving water temperature for heating mode	15E
Excessive higher discharge temperature	1F
Freezing protection of BPHE	9F
Communication failure of unit ( between Mainboard and driver )	2p
Mismatching of driver type	4p
Compressor driver alarm	6p
Excessive higher speed of fan 1	8p
Excessive higher speed of fan 2	9p
Excessive lower speed of fan 1	10p
Excessive lower speed of fan 2	11p
Inverter pump communication	12p
Inverter pump drive failure	13p
Mainboard hardware failure	14p
Mainboard and Fan1 communication failure	15P

Mainboard and Fan2 communication failure	16P
Driver hardware overcurrent	101
Compressor driving failure	102
Compressor overcurrent	103
Reserved	104
Sampling failure of compressor current	105
Heat sink/IPM overheating alarm	106
Pre-charge failure	107
DC bus over voltage	108
DC bus under voltage	109
AC input under voltage	110
AC input overcurrent	111
Driver check out failure	112
AC input hardware overcurrent	113
Driver temperature sensor fault	114
FOCx drive failure	115
FOCx/APFCx overcurrent	116

### Running Status

Press “FUNCTION” and “CONFIRM” keys for 5 seconds to enter Running Status viewing screen. The digital and analog inputs and outputs are displayed in sequence in hour display area (Area 1) by pressing “UP” and “DOWN” keys.

The modules can be switched over by pressing “TIMER” key.

Description of each running status parameters as shown in Table 21

**TABLE 13 – DESCRIPTION OF RUNNING STATUS (012~018)**

Running status No.	Description
A1	A11 Refrigerant temperature inlet accumulator
A2	A12 Saturate temperature of suction pressure
A3	A13 Discharge temperature
A4	A14 Ambient temperature
A5	A15 System leaving water temperature
A6	A16 System return water temperature
A7	A17 Unit leaving water temperature
A8	A18 Coil temperature
17	Open steps of expansion valve
21	Rotary speed of BLDC fan 1
22	Rotary speed of BLDC fan 2
23	Compressor frequency loading rate
24	Software version of Microboard
26	Software version of wire controller

**TABLE 14 – DESCRIPTION OF RUNNING STATUS (020~040)**

Running status No.	Description
A1	A11 Refrigerant temperature inlet accumulator
A2	A12 Saturate temperature of suction pressure
A3	A13 Discharge temperature
A4	A14 Ambient temperature
A5	A15 System leaving water temperature
A6	A16 System return water temperature
A7	A17 Unit leaving water temperature
A8	A18 Coil temperature
A9	A19 Economizer inlet temperature
A10	A110 Economizer outlet temperature
17	Open steps of expansion valve1
18	Open steps of expansion valve2
21	Rotary speed of BLDC fan 1
22	Rotary speed of BLDC fan 2
23	Compressor frequency loading rate
24	Software version of Mainboard
26	Software version of wire controller

#### **Fault Reset**

Press “CONFIRM” and “CANCEL” keys for 5 seconds to reset the faults manually.

#### **Keylock**

Press “TIMER” and “DOWN” icons for 5 seconds to enter Keylock function. The “LOCK” icon will appear and all touch-keys and the physical button will be disabled while the function is activated.

Press “TIMER” and “DOWN” again to terminate the function.

#### **Pump Circulation**

Press “COOLING” key for 5 seconds in daily display to enter Pump Circulation function. The “PUMP” icon will appear. The pump will operate with no compressor running while this function is activated.

#### **Low Sound Mode**

Press “CONFIRM” key for 5 seconds in temperature setting display to enable Low Sound Mode. Press “FUNCTION” and “CONFIRM” keys for 5 seconds in temperature setting display to enable Night Low Sound Mode. In Night Low Sound Mode the low sound function will only be activated during 21:00 to 6:00.

#### **Manual Defrost**

Press “COOLING” and “FUNCTION” keys for 5 seconds in temperature setting display to enter Manual Defrost setting. The modules can be selected by pressing “TIMER” and defrost will begin once pressing “CONFIRM”.

Press “CANCEL” to terminate this setting

## SECTION 5 – MAINTENANCE

It is the responsibility of the equipment owner to provide maintenance on the system.

### IMPORTANT

If system failure occurs due to improper maintenance during the warranty period, YORK will not be liable for costs incurred to return the system to satisfactory operation. The following is intended only as a guide and covers only the unit components. It does not cover other related system components which may or may not be furnished by YORK. System components should be maintained according to the individual manufacturer's recommendations as their operation will affect the operation of the unit.

### COMPRESSORS

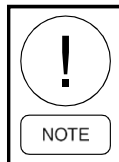
#### OIL CHARGE

The oil used in these compressors is pale yellow in color (POE oils). If one of the compressors in a refrigerant system fails to rotate and a replacement is needed, it is strongly recommended to clean the system and refill the oil. Examine the oil color during the process. If the oil darkens or exhibits a change in color, this may be an indication of contaminants in the refrigerant system.



*Never use the rotary compressor to pump the refrigerant system down into a vacuum. Doing so will cause internal arcing of the compressor motor which will result in failure of compressor.*

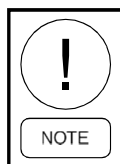
### ADD TROPICAL PREHEATING



*Air conditioning unit start up, there will be three hours compressor preheating, preheating, after the completion of the compressor to start*

### CONDENSER COILS

Dirt should not be allowed to accumulate on the condenser coil surfaces. Cleaning should be as often as necessary to keep coils clean.



*Exercise care when cleaning the coil so that the coil fins are not damaged.*

### OPERATING PARAMETERS

Regular checks of the system should be performed to ensure that operating temperatures and pressures are within limitations, and that the operating controls are set within proper limits.

### CONDENSER FAN MOTORS

Condenser fan motors are permanently lubricated and require no maintenance.

### OVERALL UNIT INSPECTION

In addition to the checks listed on this page, periodic overall inspections of the unit should be accomplished to ensure proper equipment operation. Items such as loose hardware, component operation, refrigerant leaks, unusual noises, isolators, etc. should be investigated and corrected immediately.

**MODBUS PROTOCOL**
**TABLE 15 - DEFINITIONS**

NO.	ITEM	DESCRIPTION
1	Data Flow	Communication Baud rate: 9600bps; 8-N-1: 1 start bit, 1 stop bit, check bit-none, 8 data bits; Modbus-RTU Protocol; CRC: Cyclic Redundancy Check; Hexadecimal data.
2	Master - Slave	Modbus as master; 1# microboard as slave.
3	Temperature	Unit: 0.1°C Actual temperature=Register value/10 e.g.: Cooling LWT=81, then the actual temperature is 8.1°C
4	Read/Write Mechanism	BAS need to keep communication with mainboard periodically; BAS parameter setpoint may exceed unit default range and it is required for BAS to read the setpoints from the mainboard.
5	BAS Enable	The BAS Modbus addresses of subordinates are set through HMI; Set DIP 301-7 to "ON" to make BAS enable. Set the corresponding parameters in HMI to enable and disable the BAS Start/Stop and Operating Mode functions.
6	Start/Stop Status	The Start/Stop Command (Register value = 0) is only used to start/stop the unit; Actual Start/Stop Status is accessible by reading Register value = 100.

**TABLE 16 – SYSTEM SETPOINTS**

NO.	Name	Function Code	Register Address	Note
<b>System Setpoints</b>				
1	Chiller ON/OFF	3, 6, 16	0	0-Invalid, 1-On, 2-Off
2	Mode Setting	3, 6, 16	1	0-Cooling, 1-Heating, 8-Only Pump
3	Cool Return WT Setpoint	3, 6, 16	2	10~30
4	Heat Return WT Setpoint	3, 6, 16	3	25~50
5	Cool Leaving WT Setpoint	3, 6, 16	4	5~25
6	Heat Leaving WT Setpoint	3, 6, 16	5	30~55
7	Low Sound Mode	3, 6, 16	7	1-Enabled
8	Fault Reset	3, 6, 16	8	1-Reset
9	Cooling Control Select	3, 6, 16	9	0-Fixed RT, 1-Fixed LT
10	Heating Control Select	3, 6, 16	10	0-Fixed RT, 1-Fixed LT
11	Temperature Control Cycle	3, 6, 16	11	20~120, Unit: s
12	Water Temp. Control Diff.	3, 6, 16	12	1~3

**TABLE 17 – SYSTEM PARAMETERS**

NO.	Name	Function Code	Register Address	Note
1	Chiller ON/OFF	3	100	0-OFF, 1-ON
2	System Status	3	101	0-Cooling, 1-Heating, 8-Only Pump
3	Other Status	3	102	bit0: 1-Antifreezing bit1: 1-Defrost bit2: 1-Low Sound Mode bit3: Pump Status, 1-On, 0-Off bit4: Compressor Status, 1-On, 0-Off
4	HMI Communication status	3	103	1-ON, 0-OFF
5	Unit Networks Status	3	104	bit0-16: Unit1-16, 1-On, 0-Off
6	Unit fault status	3	109	bit0-16: Unit1-16, 1-Fault
7	System Return WT	3	110	
8	System Leaving WT	3	111	
9	Ambient Temp	3	113	
10	System Loading Rate	3	114	0-100: 0-100%
11	Total Run Hours	3	117	Hr

**TABLE 18 –Fault Code**

NO.	Name	Function Code	Register Address	Note
1	Fault Word 1	3	1155(Unit 1)	Register Address Of Unit 1:1155-1162 Register Address Of Unit 2:1355-1362 Register Address Of Unit 3:1555-1562 Register Address Of Unit 4:1755-1762
2	Fault Word 2	3	1156 (Unit 1)	
3	Fault Word 3	3	1157 (Unit 1)	
4	Fault Word 4	3	1158 (Unit 1)	
5	Fault Word 5	3	1159 (Unit 1)	
6	Fault Word 6	3	1160 (Unit 1)	
7	Fault Word 7	3	1161 (Unit 1)	
8	Fault Word 8	3	1162 (Unit 1)	


**TABLE 19 – FAULT DEFINITIONS**

Address		Fault Name	Note	Class
Fault Word 1	Bit0	Inlet Accumulator Temperature Sensor Fault	Bit0: 1-Fault	Unit
	Bit1	Suction Pressure Transducer Fault	Bit1: 1-Fault	Unit
	Bit2	Discharge Temperature Sensor Fault	Bit2: 1-Fault	Unit
	Bit3	Ambient Temperature Sensor Fault	Bit3: 1-Fault	Unit
	Bit4	System Leaving Water Temperature Sensor Fault	Bit4: 1-Fault	System
	Bit5	System Return Water Temperature Sensor Fault	Bit5: 1-Fault	System
	Bit6	Unit Leaving Water Temperature Sensor Fault	Bit6: 1-Fault	Unit
	Bit7	Coil Temperature Sensor Fault	Bit7: 1-Fault	Unit
	Bit8	economizer entering temperature	Bit8: 1-Fault	Unit
	Bit9	economizer leaving temperature	Bit9: 1-Fault	Unit
Fault Word 3	Bit0	Water Flow Switch Fault Or Water Pump Overload Alarm	Bit0: 1-Fault	Unit
	Bit2	Over Pressure Alarm	Bit2: 1-Fault	Unit
	Bit4	Power Fault	Bit4: 1-Fault	Unit



Fault Word 5	Bit0	Communication Failure	Bit0: 1-Fault	Unit
	Bit1	Conflict Setting Of Unit Model Type	Bit1: 1-Fault	Unit
	Bit3	Excessive Lower Ambient Temperature For Cooling Mode	Bit3: 1-Fault	Unit
	Bit5	Excessive Lower System Leaving Water Temperature For Cooling Mode	Bit5: 1-Fault	System
	Bit6	Excessive Higher system Leaving Water Temperature For Heating Mode	Bit6: 1-Fault	System
	Bit8	Communication failure between principal unit and T8600 or BAS	Bit8: 1-Fault	Unit
	Bit9	Freezing Protection In Winter	Bit9: 1-Fault	Unit
	Bit10	Excessive Lower Unit Leaving Water Temperature For Cooling Mode	Bit10: 1-Fault	Unit
	Bit12	Excessive Higher Unit Leaving Water Temperature For Heating Mode	Bit12: 1-Fault	Unit
	Bit14	Excessive Lower Unit Leaving Water Temperature For Heating Mode	Bit14: 1-Fault	Unit
Fault Word 6	Bit0	Excessive Higher Discharge Temperature	Bit0: 1-Fault	Unit
	Bit8	Freezing Protection Of BPHE	Bit8: 1-Fault	Unit
Fault Word 7	Bit1	Communication Failure Of Unit (Between Mainboard And Compressor Driver)	Bit1: 1-Fault	Unit
	Bit3	Mismatching Of Driver Type	Bit3: 1-Fault	Unit
	Bit5	Compressor Driver Alarm	Bit5: 1-Fault	Unit
	Bit7	Excessive Higher Speed Of Fan 1	Bit7: 1-Fault	Unit
	Bit8	Excessive Higher Speed Of Fan 2	Bit8: 1-Fault	Unit
	Bit9	Excessive Lower Speed Of Fan 1	Bit9: 1-Fault	Unit
	Bit10	Excessive Lower Speed Of Fan 2	Bit10: 1-Fault	Unit
	Bit13	Mainboard Hardware Fault	Bit13: 1-Fault	Unit
	Bit14	Communication Failure Fan (Between Mainboard And 1#Fan Driver)	Bit14: 1-Fault	Unit
Bit15	Communication Failure (Between Mainboard And 2#Fan Driver)	Bit15: 1-Fault	Unit	

**TROUBLE SHOOTING**
**TABLE 20 - TROUBLESHOOTING**

PROBLEM	CAUSE	SOLUTION
No display on wire controller. Unit will not operate.	<ol style="list-style-type: none"> <li>1. No power from microboard to 12VDC wire controller.</li> <li>2. No 230VAC to microboard.</li> <li>3. Communication wire defective between wire controller to unit.</li> </ol>	<ol style="list-style-type: none"> <li>1. Check microboard power supply and the corresponding wiring.</li> <li>2. Check power supply to microboard and the corresponding wiring.</li> <li>3. Check communication wiring.</li> </ol> <div style="border: 1px solid black; padding: 5px; display: inline-block; text-align: center;">                   NOTE             </div> <p><b>Contact YORK Service before replacing circuit boards!</b></p>
<b>“Chiller Water Flow” Fault</b>	<ol style="list-style-type: none"> <li>1. No chilled liquid flow.</li> <li>2. Too much air in piping system.</li> <li>3. Flow switch improperly installed.</li> <li>4. Defective flow switch.</li> </ol>	<ol style="list-style-type: none"> <li>1. Check chilled liquid flow.</li> <li>2. Purge the air through a release valve.</li> <li>3. Check that the flow switch is installed according to manufacturer’s instructions.</li> <li>4. Replace flow switch.</li> </ol>
<b>“Low Suction Pressure” Fault</b>	<ol style="list-style-type: none"> <li>1. Low refrigerant charge.</li> <li>2. Fouled or clogged BPHE.</li> <li>3. EEV defective.</li> <li>4. Reduced flow of chilled.</li> <li>5. Defective suction pressure transducer/low pressure switch or wiring.</li> <li>6. Fans not operating (in heating mode).</li> </ol>	<ol style="list-style-type: none"> <li>1. Repair leak if necessary and add refrigerant.</li> <li>2. Clean BPHE.</li> <li>3. Check the wiring, or replace EEV.</li> <li>4. Check liquid flow rate. Check operation of pump, clean pump strainer, purge chilled liquid system of air.</li> <li>5. Replace transducer/low pressure switch or faulty wiring.</li> <li>6. Check fan wiring and communication.</li> </ol>
<b>“High Discharge Pressure or Compressor Overload” Fault</b>	<ol style="list-style-type: none"> <li>1. Condenser fans not operating or operating backwards.</li> <li>2. Too much refrigerant.</li> <li>3. Air in refrigerant system.</li> <li>4. Defective discharge pressure switch.</li> <li>5. Compressor motor locked.</li> <li>6. Compressor internal motor protector (MP) open.</li> </ol>	<ol style="list-style-type: none"> <li>1. Check fan motor. Assure fan blows air frontward.</li> <li>2. Remove refrigerant.</li> <li>3. Evacuate and recharge system.</li> <li>4. Replace discharge pressure switch.</li> <li>5. Replace compressor.</li> <li>6. Verify refrigerant charge is not low. Verify superheat setting (3-5°C). Verify correct compressor rotation. Verify compressor is not over loaded.</li> </ol>

**TROUBLE SHOOTING (CONT'D)**
**TABLE21 – TROUBLE SHOOTING (CONT'D)**

PROBLEM	CAUSE	SOLUTION
<b>“Low Leaving Water Temp” Fault</b>	<ol style="list-style-type: none"> <li>1. Improperly adjusted leaving chilled liquid temp. cutout (glycol only).</li> <li>2. Micro panel setpoint/range values improperly programmed.</li> <li>3. Chilled liquid flow too low.</li> <li>4. Defective LWT or RWT sensor (as- sure the sensor is properly installed in the bottom of the well with a generous amount of heat conductive compound).</li> </ol>	<ol style="list-style-type: none"> <li>1. Re-program the leaving chilled liquid temp. cutout.</li> <li>2. Re-adjust setpoint/range.</li> <li>3. Increase chilled liquid flow - refer to limitations in installation section.</li> <li>4. a. Compare sensor against a known good temperature sensing device. b. Replace defective sensor.</li> </ol>
<b>Compressor(s) Won't Start</b>	<ol style="list-style-type: none"> <li>1. Defective water temperature sensor.</li> <li>2. Overload failure.</li> <li>3. Driver failure.</li> <li>4. Compressor failure.</li> </ol>	<ol style="list-style-type: none"> <li>1. Compare the display with a thermometer. Should be within +/- 2 degrees.</li> <li>2. Replace defective part.</li> <li>3. Check driver running status and the flicker of LEDs.</li> <li>4. Diagnose cause of failure and replace.</li> </ol>
<b>Fan Protect</b>	<ol style="list-style-type: none"> <li>1. Power or communication loss.</li> <li>2. Internal fan fault.</li> </ol>	<ol style="list-style-type: none"> <li>1. Check the wiring;</li> <li>2. Contract local service for further fault analysis.</li> </ol>
<b>Lack of Cooling or Heating Effect</b>	<ol style="list-style-type: none"> <li>1. Fouled evaporator surface (in cooling mode). Low suction pressure will be observed.</li> <li>2. Fouled coil surface (in heating mode). Low suction pressure will be observed.</li> <li>3. Improper flow through the evaporator.</li> <li>4. Low refrigerant charge. Low suction pressure will be observed.</li> </ol>	<ol style="list-style-type: none"> <li>1. Contact the local Johnson Controls representative.</li> <li>2. Contact the local Johnson Controls representative.</li> <li>3. Reduce flow to within chiller design specs. See limitations in Installation section.</li> <li>4. Check subcooling and add charge as needed.</li> </ol>

**POISONOUS AND HARMFUL SUBSTANCE CONTENT TABLE UNIT**
**TABLE22 –POISONOUS AND HARMFUL SUBSTANCE CONTENT TABLE UNIT**

Contents of toxic and harmful substances						
Part name	hazardous substance or element					
	Pb	Hg	Cd	Cr(VI)	PBB	PBDE
Compressor	×	○	○	○	○	○
Motor	×	○	○	○	○	○
Fan	○	○	○	○	○	○
Metal Parts	○	○	○	×	○	○
Valve	×	○	○	○	○	○
Pressure Transducer	×	○	○	○	○	○
Pressure Switch	×	○	○	○	○	○
Temperature Sensor	×	○	○	○	○	○
Fastener	×	○	○	×	○	○
Controller	×	○	○	○	○	○
Electrical Control Group	○	○	○	○	○	○
Heat Exchanger	○	○	○	○	○	○
Copper Tubes	○	○	○	○	○	○
Copper Fitting	○	○	○	○	○	○
Rubber Parts	○	○	○	○	○	○
Refrigerant	○	○	○	○	○	○
Gas-liquid Separator	○	○	○	○	○	○
Aluminum Foil	○	○	○	○	○	○
Water Pump	○	○	○	○	○	○
Insulated Cotton	○	○	○	○	○	○
Soundproof Sponge	○	○	○	○	○	○
Plastic Part	○	○	○	○	○	○
Foamed Plastic Part	○	○	○	○	○	○
Printed Matter	○	○	○	○	○	○
It is based on the provisions of SJ/T11364 establishment						
○: It means the toxic and harmful substances in the parts of content in all homogeneous materials under limited requirements of GB/T26572 regulations.						
X: It means the toxic and harmful substances in the parts at least in a homogeneous material content beyond the limited requirement of GB/T26572 rules, play "x" in the form, due to technical reasons at present cannot replace, follow-up with the progress of technology will gradually improve.						
1, This product is discarded after please which is separated from the living garbage, consumers have a responsibility to be sent to the qualified collection points;						
2, Recycling center will be through the appropriate method of recycling products materials;						
3, Detailed information about recycling and disposal of this product please consult the local government, scrap processing center or local distributor;						
4, This product is not the same as the period of validity of environmental protection product safety service life.						
Suitable Model : Mini Chiller						









**YORK Guangzhou Air Conditioning & Refrigeration Co., Ltd.**

**Phone: +86 763 4681111**

**Fax: +86 763 4681114**



© 2019 Johnson Controls, Inc.

[www.johnsoncontrols.com](http://www.johnsoncontrols.com)

FROM NO: 6U5M-A11M-NB-EN

SUPERSEDES: 6U5M-A11M-NA-EN



Printed on recycled paper

\* Johnson Controls is committed to the continuous product improvement.  
Please note the product design may change without notification.

\*\*This manual is for reference only. For the specific product specifications and performance,  
Please refer to the purchase agreement.

SAP NO.: 5598564